

Consolidated*

1700 Series Maxiflow*

High Pressure Safety Valves
Maintenance Manual (Rev. D)



THESE INSTRUCTIONS PROVIDE THE CUSTOMER/OPERATOR WITH IMPORTANT PROJECT-SPECIFIC REFERENCE INFORMATION IN ADDITION TO THE CUSTOMER/OPERATOR'S NORMAL OPERATION AND MAINTENANCE PROCEDURES. SINCE OPERATION AND MAINTENANCE PHILOSOPHIES VARY, GE (GENERAL ELECTRIC COMPANY AND ITS SUBSIDIARIES AND AFFILIATES) DOES NOT ATTEMPT TO DICTATE SPECIFIC PROCEDURES, BUT TO PROVIDE BASIC LIMITATIONS AND REQUIREMENTS CREATED BY THE TYPE OF EQUIPMENT PROVIDED.

THESE INSTRUCTIONS ASSUME THAT OPERATORS ALREADY HAVE A GENERAL UNDERSTANDING OF THE REQUIREMENTS FOR SAFE OPERATION OF MECHANICAL AND ELECTRICAL EQUIPMENT IN POTENTIALLY HAZARDOUS ENVIRONMENTS. THEREFORE, THESE INSTRUCTIONS SHOULD BE INTERPRETED AND APPLIED IN CONJUNCTION WITH THE SAFETY RULES AND REGULATIONS APPLICABLE AT THE SITE AND THE PARTICULAR REQUIREMENTS FOR OPERATION OF OTHER EQUIPMENT AT THE SITE.

THESE INSTRUCTIONS DO NOT PURPORT TO COVER ALL DETAILS OR VARIATIONS IN EQUIPMENT NOR TO PROVIDE FOR EVERY POSSIBLE CONTINGENCY TO BE MET IN CONNECTION WITH INSTALLATION, OPERATION OR MAINTENANCE. SHOULD FURTHER INFORMATION BE DESIRED OR SHOULD PARTICULAR PROBLEMS ARISE WHICH ARE NOT COVERED SUFFICIENTLY FOR THE CUSTOMER/OPERATOR'S PURPOSES THE MATTER SHOULD BE REFERRED TO GE.

THE RIGHTS, OBLIGATIONS AND LIABILITIES OF GE AND THE CUSTOMER/OPERATOR ARE STRICTLY LIMITED TO THOSE EXPRESSLY PROVIDED IN THE CONTRACT RELATING TO THE SUPPLY OF THE EQUIPMENT. NO ADDITIONAL REPRESENTATIONS OR WARRANTIES BY GE REGARDING THE EQUIPMENT OR ITS USE ARE GIVEN OR IMPLIED BY THE ISSUE OF THESE INSTRUCTIONS.

THESE INSTRUCTIONS ARE FURNISHED TO THE CUSTOMER/OPERATOR SOLELY TO ASSIST IN THE INSTALLATION, TESTING, OPERATION, AND/OR MAINTENANCE OF THE EQUIPMENT DESCRIBED. THIS DOCUMENT SHALL NOT BE REPRODUCED IN WHOLE OR IN PART WITHOUT THE WRITTEN APPROVAL OF GE.

Conversion Table

USCS to Metric Conversion		
USCS Unit	Conversion Factor	Metric Unit
in.	25.4	mm
lb.	0.4535924	kg
in ²	6.4516	cm ²
ft ³ /min	0.02831685	m ³ /min
gal/min	3.785412	L/min
lb/hr	0.4535924	kg/hr
psig	0.06894757	barg
ft lb	1.3558181	Nm
°F	5/9 (°F-32)	°C

Note: Multiply the USCS value by the conversion factor to get the metric value.

NOTICE

For valve configurations not listed in this manual, please contact your local Green Tag* Center for assistance.

Table of Contents

I.	Product Safety Sign and Label System	6
II.	Safety Alerts	7
III.	Safety Notice	8
IV.	Warranty Information	9
V.	Valve Terminology	10
VI.	Handling and Storage	11
VII.	Design Features and Nomenclature	11
VIII.	Introduction	13
IX.	Consolidated 1700 Series Safety Valve	14
	A. Maxiflow Safety Valve – Flanged Inlet	14
	B. Maxiflow Safety Valve – Welded Inlet	15
	C. Valve Options	16
X.	Operating Principles	17
XI.	Recommended Installation Practices	18
	A. General Requirements	18
	B. Outdoor Safety Valve Installation	21
	C. Indoor Safety Valve Installation	22
	D. Coverplate Vent Piping	22
XII.	Disassembly of Consolidated 1700 Series Safety Valve	23
	A. General Information	23
	B. Specific Steps	23
XIII.	Maintenance Instructions	26
	A. General	26
	B. Lapping Procedure	26
	1. General Information	26
	2. To Lap the Bushing Seat	26
	3. To Lap Disc Seat	27
	C. Reseating Machine Information	28
	D. Spindle Runout	30
	E. Disc Replacement and Disc-Spindle Bearing Requirements	30
	F. Grinding the Compression Screw	32
	G. Thrust Bearing Surfaces	32
	H. Grinding the Lower Spring Washer	32
XIV.	Inspection and Part Replacement	33
	A. General Information	33
	B. Specific Steps	33

Table of Contents

1. Disc Holder	33
2. Guide	33
3. Clearance	33
4. Disc	33
5. Overlap Collar	34
6. Coverplate	34
XV. Re-Assembly of Consolidated 1700 Series Safety Valve	34
A. General Information	34
B. Specific Steps	34
XVI. Setting and Testing	41
A. Field Testing	41
A.1 General Information	41
A.2 Popping Point Adjustment	41
A.3 Ring Adjustments, Blowdown and Overlap Collar Adjustments	42
A.4 Restricted Lift Valves	45
A.5 Consolidated Hydroset/Electronic Valve Tester (EVT)	45
A.6 Sealing Valves After Test	45
B. Hydrostatic Testing and Gagging	46
XVII. Troubleshooting	47
XVIII. 1700 Series Safety Valve Options	48
A. Hydrostatic Test Plug	48
B. Hydroplug	49
XIX. Maintenance Tools and Supplies	50
A. Lapping Tools	50
A1. Ring Lap	50
A2. Lapping Plate	50
A3. Lapping Compound	50
B. Gags	50
C. Lubricant	50
D. Wrench Sizes	51
XX. Replacement Parts Planning	52
XXI. Genuine Consolidated Parts	53
XXII. Recommended Spare Parts	53
XXIII. Manufacturer's Field Service & Repair Program	55
A. Field Service	54
B. Repair Facilities	55
C. Maintenance Training	55

I. Product Safety Sign and Label System

If and when required, appropriate safety labels have been included in the rectangular margin blocks throughout this manual. Safety labels are vertically oriented rectangles as shown in the **representative examples** (below), consisting of three panels encircled by a narrow border. The panels can contain four messages which communicate:

- The level of potential harm from the hazard
- The nature of the hazard
- The consequence of human and/or product interaction with the hazard.
- The instructions, if necessary, on how to avoid the hazard.

The top panel of the format contains a signal word (**DANGER, WARNING, CAUTION** or **ATTENTION**) which communicates the level of potential harm from the hazard.

The center panel contains a pictorial which communicates the nature of the hazard, and the possible consequence of human and/or product interaction with the hazard. In some instances of risk to human health and safety the pictorial may, instead, depict what preventive measures to take, such as wearing wearing the appropriate personal protective equipment (PPE).

The bottom panel may contain instructions on how to avoid the hazard. If there is a risk to human health and safety this message may also contain a more precise definition of the hazard, and the consequences of human and/or product interaction with the hazard, than can be communicated solely by the pictorial.

①

DANGER — Immediate hazards which **WILL LIKELY** result in severe personal injury or death.

②

WARNING — Hazards or unsafe practices which **COULD** result in severe personal injury or death.

③

CAUTION — Hazards or unsafe practices which **COULD** result in minor personal injury.

④

ATTENTION — Hazards or unsafe practices which **COULD** result in product or property damage.

①



②



③



④



II. Safety Alerts



Follow all plant safety regulations, but be sure to observe the following:

- Always lower the working pressure before making any valve adjustment. When making ring adjustments, always gag the valve before making the adjustment. This will avoid possible personal injury.
- Do not stand in front of the discharge side of a safety valve when testing or operating.
- Hearing and eye protection should be used when testing or operating a valve.
- Wear protective clothing. Hot water can burn and superheated steam is not visible.
- When removing the safety valve during disassembly, stand clear and/or wear protective clothing to prevent exposure to splatter, or any corrosive process medium, which may have been trapped inside the valve. Ensure the valve is isolated from system pressure before the valve is removed.
- Exercise care when examining a safety valve for leakage.
- Prior to each actuation, assure that no personnel are near the valve. Steam escaping from the valve during actuation can possibly cause personal injury.
- When popping a safety valve for the first time, or after refurbishment, always be prepared to actuate the valve with the lever while standing in a safe place away from the valve. This may be done by fixing a rope to the lever for actuating the valve from a distance.
- Striking a valve which is under pressure can cause premature actuation. Never tamper with the valve when system pressure is near the valve set pressure.
- Before performing any machining on valve parts, consult GE or its authorized representative. Deviation from critical dimensions can adversely affect valve performance.

III. Safety Notice



Proper installation and start-up is essential to the safe and reliable operation of all valve products. The relevant procedures recommended by GE, and described in these instructions, are effective methods of performing the required tasks.

It is important to note that these instructions contain various “safety messages” which should be carefully read in order to minimize the risk of personal injury, or the possibility that improper procedures will be followed which may damage the involved GE product, or render it unsafe. It is also important to understand that these “safety messages” are not exhaustive. GE cannot possibly know, evaluate, and advise any customer of all of the conceivable ways in which tasks might be performed, or of the possible hazardous consequences of each way. Consequently, GE has not undertaken any such broad evaluation and, thus, anyone who uses a procedure and/or tool, which is not recommended by GE, or deviates from GE recommendations, must be thoroughly satisfied that neither personal safety, nor valve safety, will be jeopardized by the method and/or tools selected. Contact GE if there are any questions relative to tools/methods.

The installation and start-up of valves and/or valve products may involve proximity to fluids at extremely high-pressure and/or temperature. Consequently, every precaution should be taken to prevent injury to personnel during the performance of any procedure. These precautions should consist of, but are not limited to, ear drum protection, eye protection, and the use of protective clothing, (i.e., gloves, etc.) when personnel are in, or around, a valve work area. Due to the circumstances and conditions in which these operations may be performed on Consolidated products, and the possible hazardous consequences of each way, GE cannot possibly evaluate all conditions that might injure personnel or equipment. Nevertheless, GE does offer certain Safety Alerts, listed in Section II, for customer information only.

It is the responsibility of the purchaser or user of GE valves/equipment to adequately train all personnel who will be working with the involved valves/equipment. For more information on training schedules, call 318-640-6054. Further, prior to working with the involved valves/equipment, personnel who are to perform such work should become thoroughly familiar with the contents of these instructions.

IV. Warranty Information

⚠ CAUTION

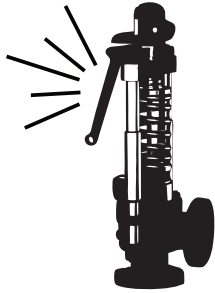

Defective and nonconforming items must be inspected by GE

⚠ CAUTION



Removal or breakage of seal will negate our warranty.

Warranty Statement

Warranty Statement⁽¹⁾ - GE warrants that its products and services will meet all applicable specifications and other specific product and service requirements (including those of performance), if any, and will be free from defects in material and workmanship.

CAUTION: Defective and nonconforming items must be held for GE's inspection and returned to the original F.O.B point upon request.

Incorrect Selection or Misapplication of Products - GE cannot be responsible for customer's incorrect selection or misapplication of our products.

Unauthorized Repair Work - GE has not authorized any non-GE affiliated repair companies, contractors or individuals to perform warranty repair service on new products or field repaired products of its manufacture. Therefore customers contracting such repair services from unauthorized sources must do at their own risk.

Unauthorized Removal of Seals - All new valves and valves repaired in the field by GE's Field Service personnel are sealed to assure the customer of our guarantee against defective workmanship. Unauthorized removal and/or breakage of this seal will negate our warranty.

⁽¹⁾ Refer to GE's Standard Terms of Sale for complete details on warranty and limitation of remedy and liability.

V. Valve Terminology (Paraphrased from ASME's PTC 25.3)

Back Pressure

Back pressure is the static pressure existing at the outlet of a safety valve device due to pressure in the discharge system.

Blowdown

Blowdown is the difference between actual popping pressure of a safety valve and actual reseating pressure expressed as a percentage of set pressure, or in pressure units.

Bore Area

Bore area is the minimum cross-sectional area of the nozzle.

Bore Diameter

Bore diameter is the minimum diameter of the nozzle.

Chatter

Chatter is abnormal, rapid reciprocating motion of the moveable parts of a safety valve, in which the disc contacts the seat.

Closing Pressure

Closing pressure is the value of decreasing inlet static pressure at which the valve disc re-establishes contact with the seat, or at which lift becomes zero.

Disc

A disc is the pressure containing moveable member of a safety valve which affects closure.

Inlet Size

Inlet Size is the nominal pipe size of the inlet of a safety valve, unless otherwise designated.

Leak Test Pressure

Leak test pressure is the specified inlet static pressure at which a quantitative seat leakage test is performed in accordance with a standard procedure.

Lift

Lift is the actual travel of the disc away from closed position when a valve is relieving.

Lifting Device

A lifting device is a device for manually opening a safety valve, by the application of external force to lessen the spring loading which holds the valve closed.

Nozzle/Seat Bushing

A nozzle is the pressure containing element which constitutes the inlet flow passage and includes the fixed portion of the seat closure.

Outlet Size

Outlet size is the nominal pipe size of the outlet passage of a safety valve, unless otherwise designated.

Overpressure

Overpressure is a pressure increase over the set pressure of a safety valve, usually expressed as a percentage of set pressure.

Popping Pressure

Popping pressure is the value of increasing inlet static pressure at which the disc moves in the opening direction at a faster rate as compared with corresponding movement at higher or lower pressures. It applies only to safety or safety relief valves on compressible fluid service.

Pressure Containing Member

A pressure containing member of a safety valve is a part which is in actual contact with the pressure media in the protected vessel.

Pressure Retaining Member

A pressure retaining member of a safety valve is a part which is stressed due to its function in holding one or more pressure containing members in position.

Rated Lift

Rated lift is the design lift at which a valve attains its rated relieving capacity.

Safety Valve

A safety valve is a pressure relief valve actuated by inlet static pressure and characterized by rapid opening or pop action opening or pop action.

Set Pressure

Set pressure is the value of increasing inlet static pressure at which a safety valve displays the operational characteristics as defined under "Popping Pressure." It is one value of pressure stamped on the safety valve.

Seat

A seat is the pressure containing contact between the fixed and moving portions of the pressure containing elements of a valve.

Seat Diameter

Seat diameter is the smallest diameter of contact between the fixed and moving members of the pressure containing elements of a valve.

Seat Tightness Pressure

Seat tightness pressure is the specific inlet static pressure at which a quantitative seat leakage test is performed in accordance with a standard procedure.

Simmer

Simmer is the audible or visible escape of fluid between the seat and disc at an inlet static pressure below the

popping pressure and at no measurable capacity. It applies to safety valves on compressible fluid service.

Warn

See "Simmer" (definition above).

VI. Handling and Storage

Safety valves should be stored in a dry environment and protected from the weather. They should not be removed from the skids or crates until immediately prior to installation. Flange protectors and sealing plugs should remain installed until just prior to installation.

Safety relief valves, either crated or uncrated, should never be subjected to sharp impact. This would be most likely to occur by bumping or dropping during loading or unloading from a truck or while moving with a power conveyor, such as a fork lift truck. The valve, either crated or uncrated, should always be kept with the inlet down (i.e., never laid on its side), to prevent misalignment and damage to internal components. Even crated valves should always be lifted with the inlet down.

Uncrated valves should be moved or hoisted by wrapping a chain or sling around the discharge neck, then around the upper yoke structure, in such manner as will ensure the valve is in a vertical position during lift. Never lift the full weight of the valve by the pilot assembly, tubing, lifting lever or other external device.

Never hook to the spring to lift. When safety valves are uncrated and the flange protectors removed, immediately prior to installation, meticulous care should be exercised to prevent dirt from entering the outlet port while bolting in place. While hoisting to the installation, care should be exercised to prevent bumping the valve against steel structures and other objects.

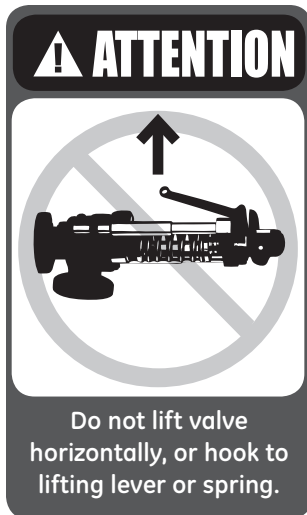

VII. Design Features and Nomenclature

Blowdown

The Consolidated Maxiflow Safety Valve is the valve with 3% attainable blowdown certified by the National Board of Boiler and Pressure Vessel Inspectors.

Adjusting rings are preset at the factory to give slightly longer blowdown. If a verified value of 3% blowdown is required, this can be obtained by actuating the valve on the installation where sufficient capacity is available, and where system operating parameters will permit such blowdown.

Body and Neck Materials

All pressure retaining parts, with the exception of reheat valves rated to 900 psig (62.05 barg) and lower, are made of forged materials. Forged welded inlet neck valves have the three-piece weld construction. Flanged inlet valves and cast neck welded inlet valves have a top-inserted seal-welded bushing.

Design Life

For most service conditions, pressure retaining parts subject to mechanical stresses, such as valve necks, yoke rods, etc, are designed for a design life equivalent to the boiler, and are well in excess of the requirements of the Power Boiler Code.

Operating Gap

The operating gap is defined as the difference between the operating pressure and the valve set pressure. Consolidated Safety Valves are tested and proven tight for operating gaps of 6%. Although tightness is a function of design, it should be realized that with smaller operating gaps it is also necessary to increase maintenance. Increase in incidents of valve lift, simmer, etc can be expected with a small operating gap, because there is less allowance for system pressure transients and other unidentified variables

Supercritical Valves

Maxiflow Supercritical Valves are used for steam at pressures above approximately 3200 psig (220.63 barg). Its internal design is similar to that used in subcritical boiler safety valves. The springs for supercritical valves are made from alloy steel, the discs from Inconel "X" and the seating surface of the bushing from Stellite. These materials have been found to work very well under the high temperatures and pressures to which the valves are subjected. A ball thrust bearing is used on the compression screw in all of the valves for better adjustment.

Thermal Compensation

The yoke rod design, together with proper selection of yoke rod and spindle materials, renders the valve relatively free from changes in pressure settings due to inlet temperature variations. High ambient temperatures adjacent to the valve spring and yoke rods may cause set pressure variations, and need to be considered when adjusting the valve. Temperature stabilization is always necessary prior to adjusting a valve for set pressure

Thermoflex* disc

The Thermoflex disc design, by allowing for the rapid equalization of temperature around the valve seat, provides a degree of tightness far above that offered by competitive valves. Selection of materials provides desired "Thermal Flexibility" and "Mechanical Flexibility". Thermoflex™ discs are now giving excellent results at 5500 psig (379.21 barg) and 1150°F (621°C).

VIII. Introduction

The “safety valve” is the final safeguard between a controlled boiler and a catastrophic explosion. In an overpressure situation, the pressure in the valve inlet increases until the force on the disc exerted by the system pressure equals the force exerted by the spring. This causes the safety valve to pop, or lift, relieving the excess steam until the system pressure is reduced to the desired level.

The Type 1700 Maxiflow Safety Valve represents the state of the art in pressure relief products. As well as its back pressure assisted closing feature, the Maxiflow Safety Valve incorporates a pressure assisted/temperature stabilizing Thermoflex disc for improved seat tightness. This design has been proven in hundreds of installations world wide.

The Type 1700 Maxiflow Safety Valve is sold with a flanged outlet and either a flanged or buttwelded inlet. Other variations include a thrust bearing assisted compression screw for high pressure valves, a spring cover and a lifting gear cover for outdoor installations. All export and weld inlet valves are shipped with a hydro plug for protecting the internal parts of the valve and to provide a means for the end user to hydrostatically test the system without damaging the disc or nozzle seats. The information contained in this manual provides the customer with basic concepts required in maintenance of the Maxiflow Safety Valve, but in no way is it intended to take the place of experience and technical knowledge required to perform adequate valve repair work and maintenance.

IX. Consolidated 1700 Series Safety Valve

A. Maxiflow Safety Valve – Flanged Inlet [1500 psig (103.4 barg) Class]

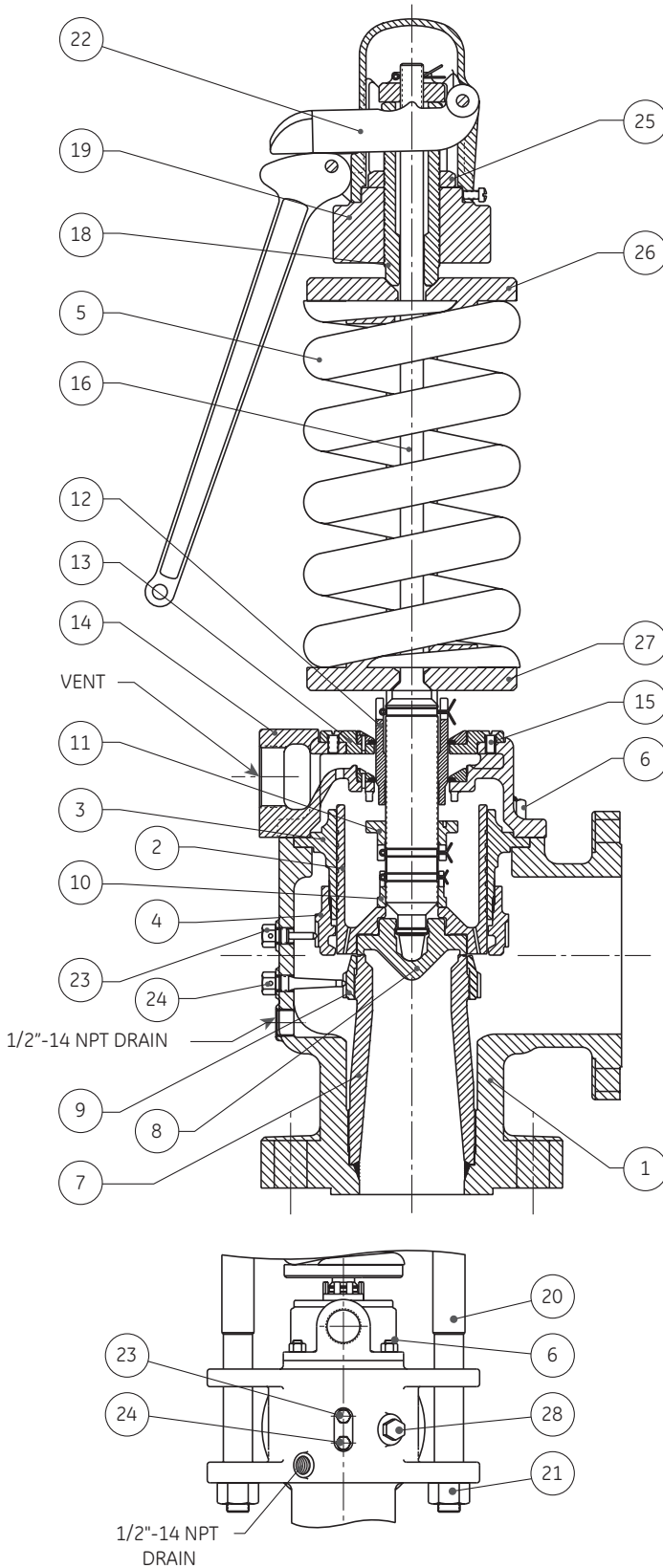

Part No.	Nomenclature
1	Base
2	Disc Holder
3	Guide
4	Upper Adjusting Ring
5	Spring
6	Coverplate Stud
7	Seat Bushing
8	Disc
9	Lower Adjusting Ring
10	Disc Collar
11	Lift Stop
12	Overlap Collar
13	Coverplate Assembly
13a	Coverplate
13b	Floating Washer
13c	Washer Retainer
13d	Drive Screws
13e	Coverplate Nut
14	Top Plate Assembly
14a	Top Plate
14b	Washer Retainer
14c	Floating Washer
14d	Drive Screws
15	Top Plate Screws
16	Spindle
17	Spindle Button ¹
18	Compression Screw
19	Yoke
20	Yoke Rod
21	Yoke Rod Nut
22	Lifting Gear
23	Upper Adjusting Ring Pin
24	Lower Adjusting Ring Pin
25	Compression Screw Locknut
26	Upper Spring Washer
27	Lower Spring Washer
28	Service Plug
29	Thrust Bearing ²
30	Compression Screw Adaptor ³
31	Thrust Bearing Cover ⁴

Notes:

1. For 1719 valve only.
2. For 1786-HP, 1706RR-HP, 1719, 1729, 1769 valves only
3. For 1786-HP, 1706RR-HP, 1729, 1769 valves only
4. For 1769 valve only

Figure 1: 1700 Maxiflow Safety Valve – Flanged Inlet

IX. Consolidated 1700 Series Safety Valve (Contd.)

B. Maxiflow Safety Valve – Welded Inlet [600 psig (41.37 barg) Class]

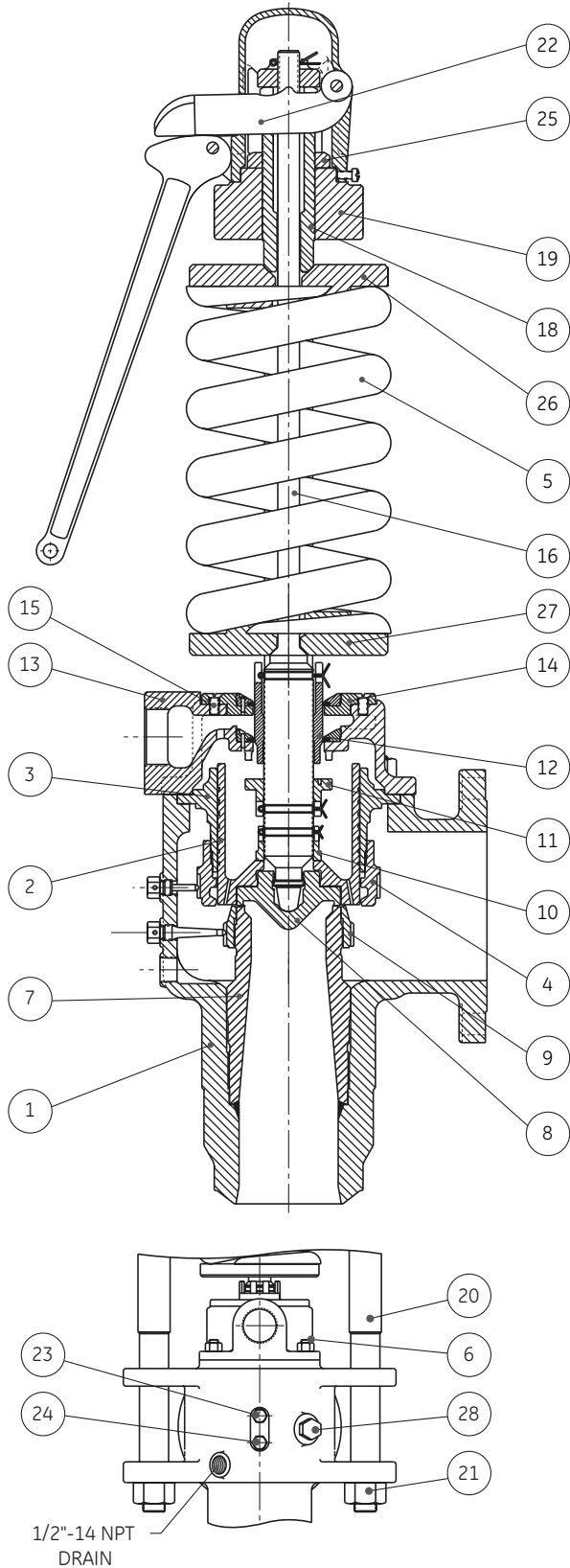

Part No.	Nomenclature
1	Base
1a	Inlet Neck
2	Disc Holder
3	Guide
4	Upper Adjusting Ring
5	Spring
6	Coverplate Stud
7	Seat Bushing
8	Disc
9	Lower Adjusting Ring
10	Disc Collar
11	Lift Stop
12	Overlap Collar
13	Coverplate Assembly
13a	Coverplate
13b	Floating Washer
13c	Washer Retainer
13d	Drive Screws
13e	Coverplate Nut
14	Top Plate Assembly
14a	Top Plate
14b	Washer Retainer
14c	Floating Washer
14d	Drive Screws
15	Top Plate Screws
16	Spindle
17	Spindle Button ¹
18	Compression Screw
19	Yoke
20	Yoke Rod
21	Yoke Rod Nut
22	Lifting Gear
23	Upper Adjusting Ring Pin
24	Lower Adjusting Ring Pin
25	Compression Screw Locknut
26	Upper Spring Washer
27	Lower Spring Washer
28	Service Plug
29	Thrust Bearing ²
30	Compression Screw Adaptor ³
31	Thrust Bearing Cover ⁴
32	Comp. Scr. Locknut Set Screw ⁵

Notes:

1. For 1719, 1710, 1760 valves only
2. For 1786-HP, 1706R-HP, 1706RR-HP, 1787, 1707R, 1707RR, 1719, 1729, 1710, 1720, 17_3 valves only
3. For 1786-HP, 1706R-HP, 1706RR-HP, 1787, 1707R, 1707RR, 1729, 1710, 1720, 17_3 Valves only
4. For 17_3 valves only
5. Standard for 17_0W and 17_3W valves only; valves 17_7W and 17_9W for set pressures **greater than** 2500 psig (172.37 barg) only

Figure 2: 1700 Maxiflow Safety Valve – Welded Inlet

IX. Consolidated 1700 Series Safety Valve (Contd.)

C. Valve Options

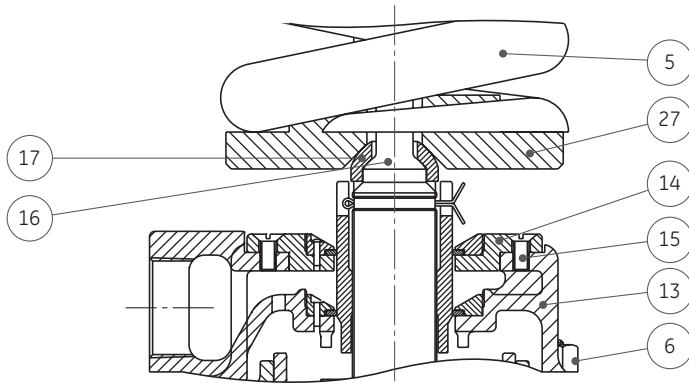

Figure 3: Spindle Button

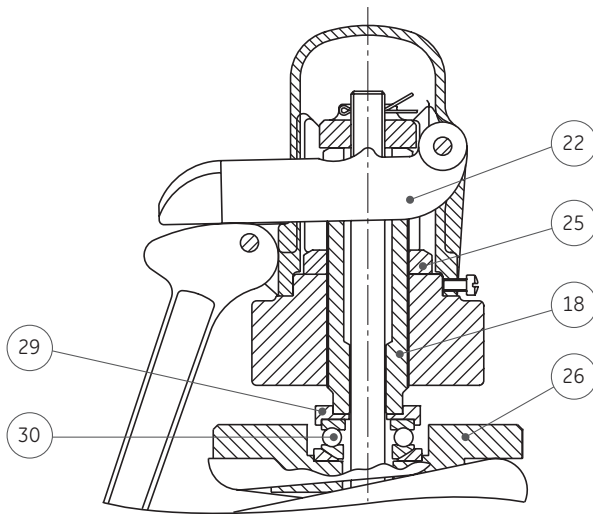

Figure 4: Thrust Bearing

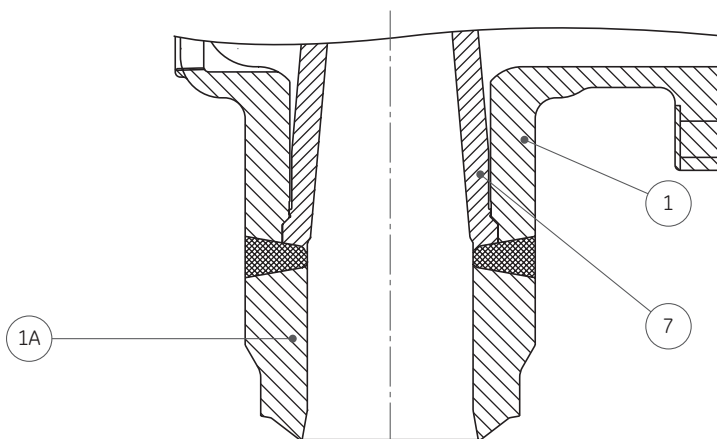

Figure 5: Inlet Neck

Part No.	Nomenclature
1	Base
1a	Inlet Neck
5	Spring
6	Coverplate Stud
7	Seat Bushing
13	Coverplate Assembly
13a	Coverplate
13b	Floating Washer
13c	Washer Retainer
13d	Drive Screws
13e	Coverplate Nut
14	Top Plate Assembly
14a	Top Plate
14b	Washer Retainer
14c	Floating Washer
14d	Drive Screws
15	Top Plate Screws
16	Spindle
17	Spindle Button ¹
18	Compression Screw
22	Lifting Gear
25	Compression Screw Locknut
26	Upper Spring Washer
27	Lower Spring Washer
29	Thrust Bearing ²
30	Compression Screw Adaptor ³

Notes:

1. For 1719, 1710, 1760 valves only
2. For 1786-HP, 1706R-HP, 1706RR-HP, 1787, 1707R, 1707RR, 1719, 1729, 1710, 1720, 17_3 valves only
3. For 1786-HP, 1706R-HP, 1706RR-HP, 1787, 1707R, 1707RR, 1729, 1710, 1720, 17_3 valves only

X. Operating Principles

The 1700-S series Maxiflow valve operates during closing on a back pressure principle, that is, the force of trapped steam on the upper side of the disc holder is utilized to assist the spring in forcing the disc back down onto its seat.

In Figure 6, 100% lift is attained by proper location of the upper and lower adjusting rings (G) and (O), respectively. When full lift is attained, as in Figure 7, lift stop (M) rests against coverplate (P) to eliminate hunting, thus adding stability to the valve. When the valve discharges in an open position, steam is bled into

chamber (H) through two bleed holes (J) in the roof of the disc holder. Similarly, the spindle overlap collar (K) rises to a fixed position above the floating washer (L). The area between the floating washer and the spindle is thereby increased by the difference in the two diameters on the overlap collar. Under this condition, steam in chamber (H) enters into chamber (Q) through the secondary area formed by the floating washer (L) and the overlap collar (K) on the spindle, then through orifice (N), and escapes to atmosphere through the pipe discharge connection (R).

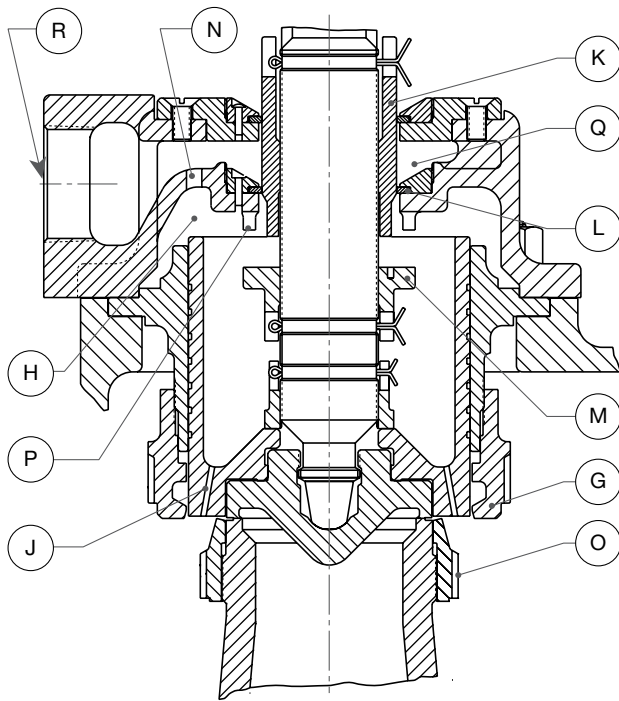

Figure 6: 100% Lift

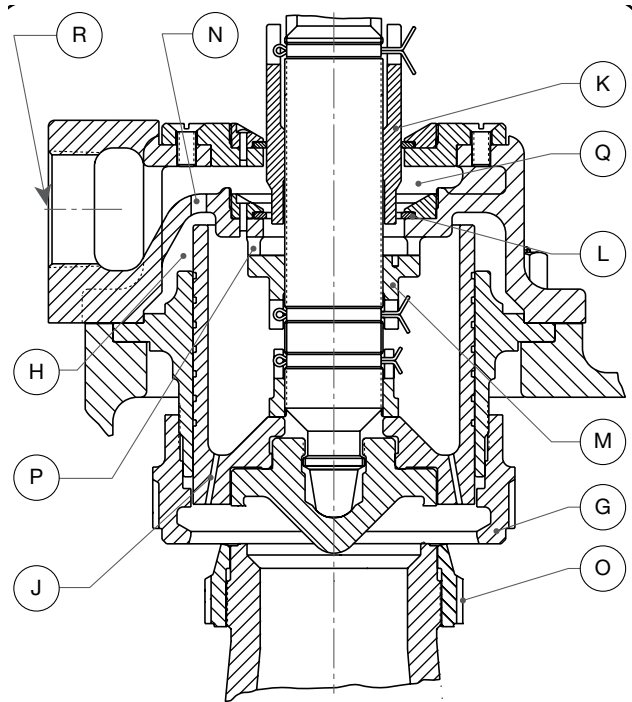

Figure 7: Full Lift

When closing, as in Figure 8, the spindle overlap collar (K) is adjusted so that it moves down into the floating washer (L), thereby effectively reducing the escape of steam from chamber (H).

The resulting momentary pressure building-up in chamber (H), at a rate controlled by orifice (N), produces a downward thrust in the direction of spring loading. The combined thrust of the pressure and spring loading results in positive and precise closing. Cushioning of the closing is controlled by the lower adjusting ring (O).

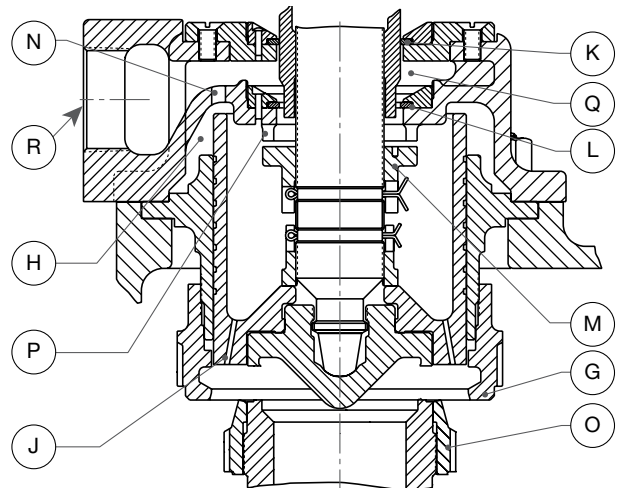

Figure 8: Closing

XI. Recommended Installation Practices

A. General Requirements

1. The valve should be installed to meet all the requirements of Figure 9 and Table 1.
2. The safety valve shall be connected to the header independent of any other connection, and attached as close as possible to the header, without any unnecessary intervening pipe or fitting. "Necessary" intervening pipe or fitting shall not be longer than the face-to-face dimension of the corresponding tee fitting of the same diameter and pressure, per ANSI Standards.
3. No valve of any description should be placed between the safety valve and the header, nor on the discharge pipe between the safety valve and the atmosphere.
4. In no case may the inlet piping to the valve have a flow area less than the area of the valve inlet.
5. Excessive pressure loss at the inlet of the safety valve will cause extremely rapid opening and

closing of the valve, which is known as "chattering". Chattering will result in lowered capacity as well as damage to the seating surface of the valve. Severe chattering can cause damage to other parts of the valve.

Table 1: Maximum L Dimension				
Inlet Size		Outlet Class	L max.	
in.	mm		in.	mm
3.00	76.2	150 #	7.250	184.15
4.00	101.6	300 #	9.375	238.13
6.00	152.4	150 #	12.500	317.50
6.00	152.4	300 #	12.875	327.03
8.00	203.2	150 #	16.000	406.40
8.00	203.2	300 #	16.375	415.93
10.00	254.0	150 #	19.000	482.60

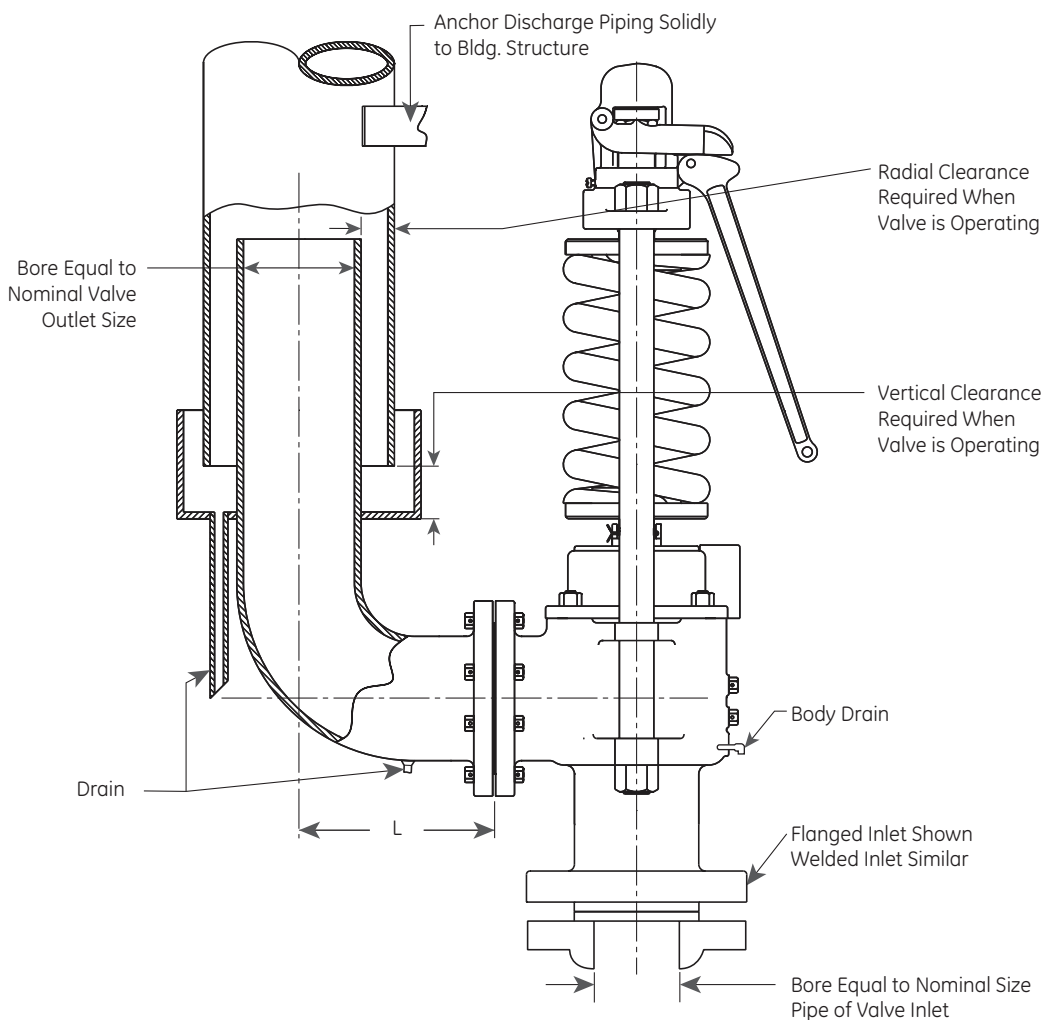

Figure 9: Recommended Installation for Discharge and Vent Piping

XI. Recommended Installation Practices (Contd.)

The following recommendations will assist in eliminating the factors that produce chatter:

- a. Header nozzle corners must be rounded to a radius of not less than 1/4 of the opening diameter.
 - b. Pressure drop due to friction flow to the inlet of the valve should not be greater than 50 percent of the expected blowdown of the safety valve.
6. To decrease the effects of a phenomenon known as “sonic vibrations,” the following recommendations are made:
- a. Safety valves should be installed at least eight to ten pipe diameters downstream from any bend in a steam line. This distance should be increased when the valve is installed on the horizontal section of a header which is preceded by an upward section.
 - b. Safety valves should not be installed closer than eight to ten pipe diameters either upstream or downstream from a diverging, or a converging, “Y”.
 - c. In cases where a piping configuration renders the above two recommendations impractical, or impossible, the downstream corner of the header nozzle inlet should be rounded to a greater extent than the upstream corner. The header nozzle entrance should be rounded so the radius at the downstream corner will be equal to a minimum of 1/4 of the nozzle diameter. The radius should be reduced gradually, leaving only a small portion of the upstream corner with a smaller radius.
 - d. Safety valves should never be installed, in a steam line, in a position directly opposite to a branch line.
7. Excessive line vibrations are known to produce shifts in safety valve set pressures. Vibrations may possibly introduce chatter, causing damage to the valve, and reduce its capacity. This vibration also contributes to increased incidents of seat leakage. Considerations should be given to eliminating this problem prior to installing the valve on the unit.
8. Steam flowing vertically out a discharge elbow produces a downward reaction on the elbow. Bending stress in the valve is determined by the product of this reactive force and the moment arm between the point of steam exhaust and the section being analyzed for bending stress. The effects of reaction force, vibration, and seismic loads, on all valve components and discharge piping, should be considered when designing the valve system.
9. For optimum performance, safety valves must be serviced regularly and otherwise maintained. So that servicing can be properly performed, valves should be located in a manner that allows for easy access. Sufficient working space should be provided around and above the valve to permit access to adjusting rings. If two or more valves are located close together, the outlets should be parallel so as to offer as much protection as possible to personnel repairing, or working close to, the safety valve.
10. Because foreign material passing into, and through, a safety valve is damaging, the system on which the valve is tested and finally installed must also be inspected and cleaned. New systems are prone to contain welding beads, pipe scale and other foreign materials which are inadvertently trapped during construction, and destroy the valve seating surfaces the first few times the valve opens. Therefore, the system should be thoroughly purged before the safety valve is installed.
11. With regard to weld-end inlet valves, completely assembled valves may be installed without disassembly being necessary at the time of welding. During welding, the valve neck should be insulated to reduce thermal stresses. When stress relieving, insulation should also be utilized to reduce thermal stresses. In service, the valve neck should be insulated at least to the point of the inlet neck/valve body-bowl juncture.
12. Safety valves should be installed in a vertical position. Nominal tolerance on vertical installation is plus or minus 1 degree.
13. The discharge area of the outlet piping from a safety valve should not be less than the area of the outlet connection. Where more than one safety valve is connected to a common outlet pipe, the area of the pipe should not be less than the combined area of the outlet connections to the safety valves.
14. All safety valve discharges should be piped so that the effluent is discharged clear from running boards or platforms. Ample provision for gravity drain should be made in the discharge pipe at, or near, each safety valve where water, or condensation, may collect. Each valve has an open

XI. Recommended Installation Practices (Contd.)

gravity drain through the body, below the level of the valve seat, and this drain should be piped to a safe discharge area.

15. If a silencer is used on a safety valve, it should have sufficient outlet area to prevent back pressure from interfering with the proper operation and discharge capacity of the valve. The silencer or other piping components should be constructed so as to avoid the possibility of creating corrosion deposit restrictions in the steam passages.
16. Exhausts, drains, and vents must be installed so that they will not impose undue stresses on the safety valve. Any such stresses can produce body distortion and leakage. Therefore, the following recommendations are provided:
 - a. Discharge piping should not be supported by the valve. The maximum weight on the outlet of the valve should not exceed the weight of a short radius elbow and flange, plus a 12" (304.8 mm) straight length of standard weight thickness pipe (with drip pan).
 - b. Clearance between the valve exhaust piping and the discharge stack should be sufficient to prevent contact when considering thermal expansion of the header, valve, and discharge stack. Movements due to vibration, temperature changes, and valve reaction forces should also be considered, to insure adequate clearance between the exhaust piping and the discharge stack.
 - c. Flexible metal hoses are not generally recommended, but if used to connect valve outlets to discharge stacks, they must be of sufficient length, and be configured/installed in such a manner, that they will not become "solid" in anyone position. Better results are obtained if the hoses are installed so that they will permit movement by bending, rather than by stretching and compressing along their length.
17. When lifting a valve, the valve should always remain in a vertical position. The valve may be lifted by using a sling around the valve yoke and the valve outlet neck. In no case should the valve be lifted by the lifting lever.

The valve should not be bumped or dropped during installation. If the valve is dropped, an inspection for damage should be made, and the set pressure of the valve rechecked.

18. At the time of installation, all protective covers on the valve should be removed. The internal of the valve are to be checked for cleanliness. No foreign matter is permitted in the valve inlet or outlet, since it may possibly damage the valve components, or be dropped into the header.

All face surfaces which require gaskets, to seal pressure, shall be inspected for cleanliness, or any defects that can cause leakage. Burrs, mashed serrations, uneven surfaces, etc., are all possible leakage-producing defects. Proper gasket sizes and pressure ratings should be checked prior to starting valve installation.

19. It is of utmost important that the gaskets used be dimensionally correct for the specific flange, and that they fully clear the valve inlet and outlet openings. Gaskets, flange facings, and bolting should meet the service requirements for the pressure and temperature involved. Other valve installation considerations include:
 - a. Install the inlet gasket, if required, on the header mounting flange. Check for cleanliness, surface alignment condition, gasket condition, etc. When possible, inlet studs on the mounting flange should be used to guide the valve on the header mounting flange. Inlet studs should be lubricated with the appropriate lubricant.
 - b. When installing flanged valves, the flange bolts must be pulled down evenly to prevent body distortion, misalignment, and leakage.
 - c. With valve in position, screw on the stud nuts until all nuts are finger tight. An initial torque shall be placed, in turn, on each stud nut. Increase the torque progressively until the final torque is applied. Upon completion, recheck each stud nut's torque. Required torque will vary with bolting material and gaskets used. See your company engineering or specification department for details.

As an extra precaution, the gap between the two mating flanges should be checked during the torquing process to ensure that the flanges are being pulled together evenly. Calipers may be used for this verification. A final inspection and review should be made to insure that all of the requirements for bolting the valve inlet have been implemented.

XI. Recommended Installation Practices (Contd.)

- d. In like manner, the outlet piping may now be installed.
A complete inspection of components and their cleanliness is to be made prior to further work. Studs are to be lubricated with an appropriate lubricant.
 - e. Install the outlet gasket, studs and nuts. Stud nuts are to be pulled down finger tight. An initial value of torque is to be applied. The additional procedures outlined, in Step 19c, are also to be followed.
20. After being assured that the valve is properly installed, the drainage piping from the valve body-bowl is to be connected. This line also must be flexible, so it will not create loads on the valve under operating conditions.
 21. Prior to completing the installation, a visual check should be made to ensure that the valve lifting lever is free to operate.
 22. At the time of installation, an inspection of the valve should be made to confirm that all adjustment components (i.e., ring pins, cap, etc.) are properly locked and sealed, as required by the ASME Code.
 23. Flanged valves may be installed without insulation.
 24. For operational hydrostatic tests at the valve inlet, which do not exceed valve set pressure (1.0 x design pressure), the valve may be gagged. Refer to the "Field Testing" portion of this manual (i.e., Section XIII.A) for proper techniques. Ensure that the gag is removed upon completion of the inlet hydrostatic test.
 25. Prior to startup of the unit on steam, the sections of this manual which specify requirements for set pressure testing should be reviewed. For conditions where the valve is subjected to high steam pressures (i.e., those exceeding normal operating conditions), preparations should be made to gag the valves. These preparations should then be cleared with the boiler manufacturer and GE. Refer to Section XVI.A of this manual for the proper gagging techniques.
 26. The safety valve should be tested with full steam pressure to ensure that the safety valve installation has been properly accomplished. In some cases this is not practical, thus the use of Consolidated

Hydroset device or Electronic Valve Tester (EVT*) unit should be considered. For valves being tested for set pressure by using a Hydroset device or EVT unit only, the set pressure is being verified. Other factors such as blowdown, lift, reaction force, proper discharge stack sizes and effects of thermal expansion cannot be determined.

27. Vent and drain piping should have a union connection to facilitate valve removal.

B. Outdoor Safety Valve Installation

Safety valves operating under the best possible conditions (i.e., of favorable operating gap, relatively stable ambient temperatures, the absence of dirt and in relatively still air) will provide the maximum degree of safety, tightness and dependability.

When a safety valve is installed in an outdoor location, it may be exposed to wind, rain, snow, ice, dirt and varying temperatures. Therefore, the following recommendations are made for proper protection, and to ensure that operational dependability can be restored to a level near that of the valve installed under ideal conditions:

1. The inlet neck of the safety valve and safety valve body, up to the bottom of the coverplate, should be insulated. In some cases, it may be sufficient to insulate the inlet neck of the safety valve and bottom of the base only (CAUTION: Do not insulate the safety valve spring). The exterior surface of any such insulation should be made weather-proof by any suitable means. In addition to maintaining a more even temperature within the valve body, especially during widely fluctuating ambient temperatures, this insulation will effectively reduce thermal stresses, due to high temperature gradients, through the walls of the safety valve nozzle.
2. Spring covers should be used to stabilize (as nearly as possible) the temperature of the spring, to prevent the accumulation of snow and ice between the coils of the spring, and to prevent dirt and fly ash from accumulating between the coils of the spring.
3. Lifting gear covers should be installed to prevent ice, dirt and fly ash from accumulating in areas inside the safety valve cap.

XI. Recommended Installation Practices (Contd.)

⚠ WARNING



Know possible steam exhaust/leakage points to avoid possible severe personal injury or death.

⚠ ATTENTION



Handle valve carefully. Do not drop or strike.

C. Indoor Safety Valve Installation

Indoor valve installations should have inlet necks insulated only up to the underside of the valve body. Considerations should be given to ambient temperatures greater than 100°F (37°C), because of possible set point changes which may occur due to these higher ambient temperature.

D. Coverplate Vent Piping

The coverplate can be vented to atmosphere as shown in Figure 10. Precautions should be taken to vent the coverplate in such a manner that it will exhaust into a safe area to prevent injury to personnel near the valve. The coverplate vent drain must not be connected to the body drain piping.

Do not plug the coverplate vent hole or reduce vent hole pipe size, as this will lead to valve malfunction and damage.

Precautions should be taken to prevent accumulations of foreign material or water in vent pipe. This vent is a critical part of the valve system for controlling valve blowdown and lift.

Note: Appropriate considerations should be made for draining any condensate which may accumulate in the coverplate vent piping.

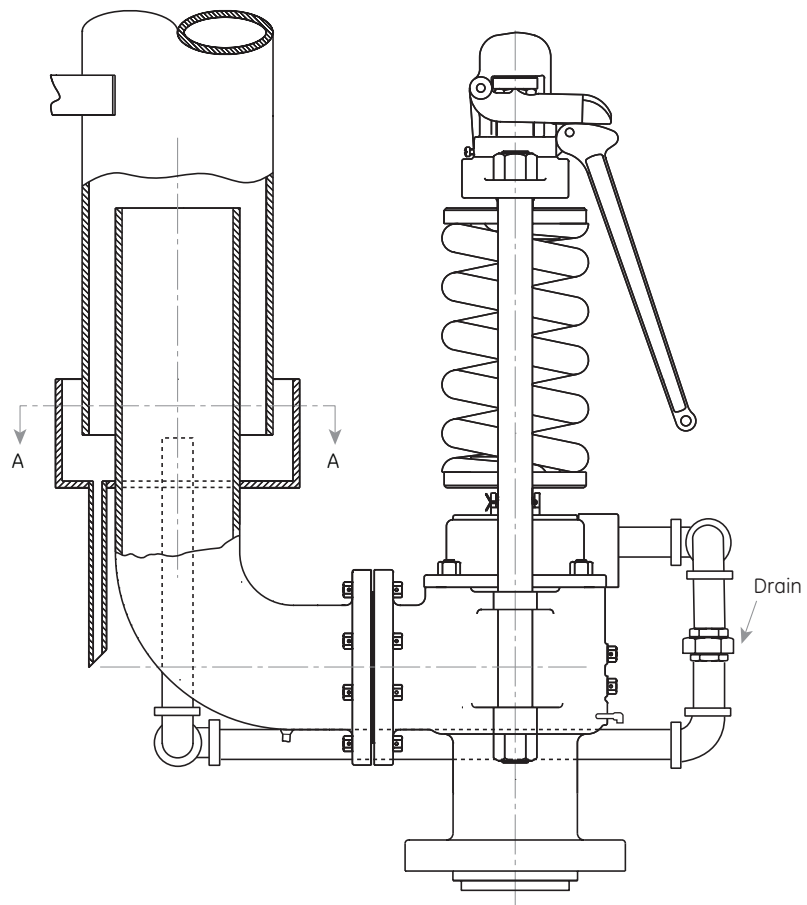

Figure 10: Recommended Installation

XII. Disassembly of 1700 Series Safety Valve

A. General Information

The 1700 Series Maxiflow Safety Valve can be easily disassembled for inspection, reconditioning seats, or replacing internal parts. The initial spring load can be established after reassembly (Refer to Figures 1 to 5 for parts nomenclature).

Note: Before starting to disassemble the valve, be sure that there is no steam pressure in the drum or header.

Parts from one valve should not be interchanged with parts from another valve.

**Note for valves used in ATEX conditions:
A maintenance schedule for spring replacement every second outage, not to exceed four (4) years is required.**

B. Specific Steps

1. Remove the top lever pin and top lever.
2. Loosen cap set screw and lift off cap and drop lever assembly.
3. Remove the cotter pin which retains the release nut, and then remove the release nut.
4. Refer to Figure 11, and measure and record Dimension A, as this information will be required to correctly re-assemble the valve.
5. Remove the two top yoke rod nuts evenly, so as to prevent binding of the yoke.
6. Carefully lift the yoke over the spindle, and away from the valve. Remove the thrust bearing assembly (if applicable) and the top spring washer.

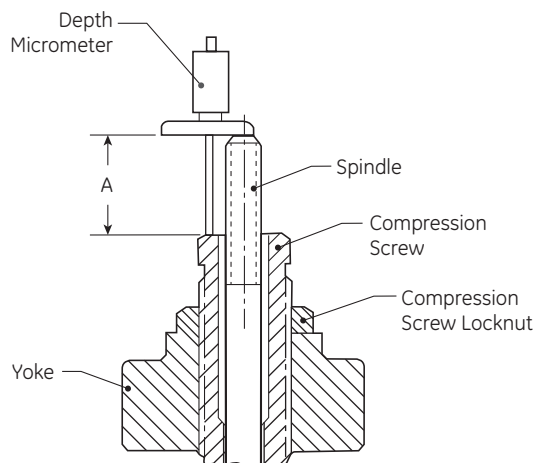

Figure 11: Yoke-Spindle Assembly

7. Ensure that the bottom spring washer is not stuck to the spring. If the bottom spring washer is stuck to the spring it may accidentally jar loose and fall. Next, mark the top of the spring, in order to correctly install the spring during re-assembly. Finally, lift the spring over the spindle and away from the valve, and then remove the bottom spring washer.
8. Remove the overlap collar cotter pin from the collar and spindle assembly. Note which overlap collar notch is opposite the cotter pin hole in the spindle (See Figure 12). Carefully counting each collar notch that passes in front of the cotter pin hole in the spindle, begin rotating the collar counterclockwise until the bottom line (of the four lines) on the collar is even with the upper floating washer. Record the number of overlap collar notches that passed in front of the cotter pin hole in the spindle, as this information will be required to correctly re-assemble the valve.
9. Mark the coverplate vent to establish its relationship to the valve base, as this will ensure correct alignment during re-assembly. Then, remove the coverplate stud nuts and lift the coverplate over the studs.
10. Remove the spindle, disc and disc holder assembly from the valve by lifting the spindle. Take care to ensure that the disc seating surface is not damaged when the assembly is placed on the ground or some other work surface.

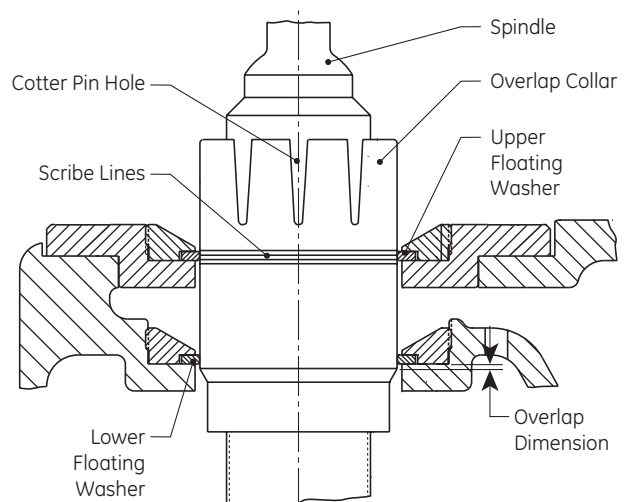

Figure 12: Collar and Spindle Assembly

XII. Disassembly of 1700 Series Safety Valve (Contd.)

- To remove the disc and disc holder from the spindle, first insert the spindle into a vise (see Figure 13) being careful not to damage the threaded end of the spindle. Then, lift up on the disc holder and turn the disc/disc holder counterclockwise to engage the “drop-thru” threads. Once the threads are engaged, release the disc holder and continue to unthread and remove the disc. After the disc is removed, lift the disc holder from the spindle.

Note: Removal of the overlap collar, the lift stop and/or the disc collar from the spindle is usually unnecessary, unless the spindle is to be replaced.

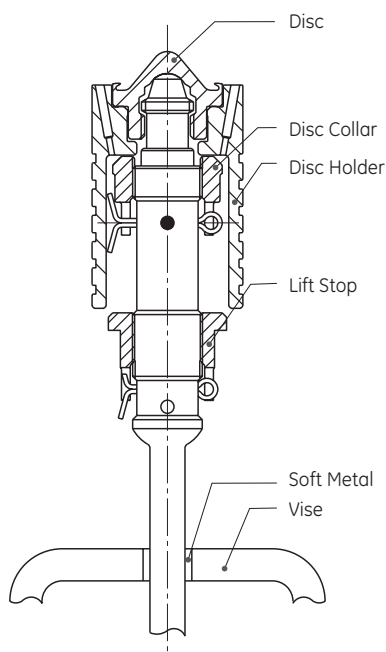

Figure 13: Spindle Vise

- Measure from the top of the guide to the bushing seat (Dimension B, Figure 14) with a depth micrometer or other suitable measuring device. **Record Dimension B.** Place a scale or other thin flat metal surface against the lower face of the upper adjusting ring and measure from the top of the guide to the face of the upper adjusting ring (Dimension C, Figure 14). **Record Dimension C.**
- Remove the upper adjusting ring pin from the valve base. Remove the upper adjusting ring and guide assembly from the base by lifting straight up on the guide being careful not to disturb the upper adjusting ring adjustment. **Mark the radial position of the upper ring notches** relative to the

guide by marking or scribing axially on the guide, then making a corresponding mark axially on the upper adjusting ring (see Figure 15). Recording Dimensions B and C and marking of the upper adjusting ring and guide will aid in setting the adjusting ring in exactly the same position it was in prior to disassembly.

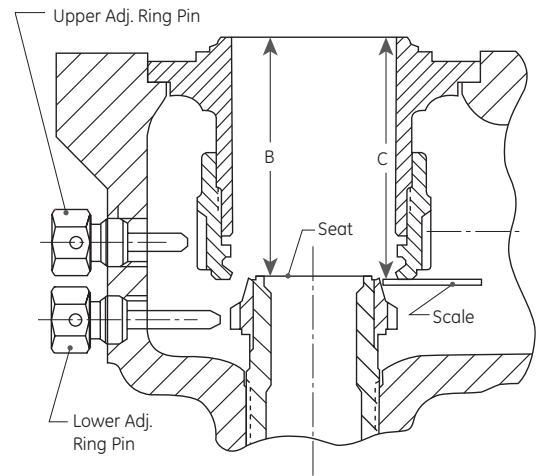

Figure 14: Guide - Bushing Seat Assembly

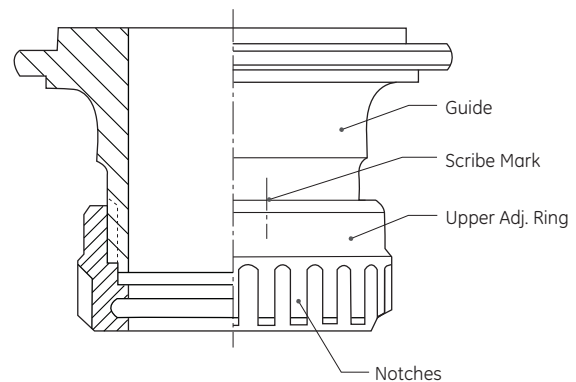

Figure 15: Upper Adjusting Ring and Guide Assembly

- Loosen the lower adjusting pin until the pin is slightly clear of the notches in the lower adjusting ring. Being careful not to move the lower adjusting ring, place a ring lap on top the bushing seat. (See Figure 16). Then, using the ring pin as a “pointer”, or reference point, rotate the lower adjusting ring counterclockwise and count the number of notches that pass in front of the “pointer” until contact is made with the ring lap. Record this information, as it will be required to correctly re-assemble the valve.

XII. Disassembly of 1700 Series Safety Valve (Contd.)

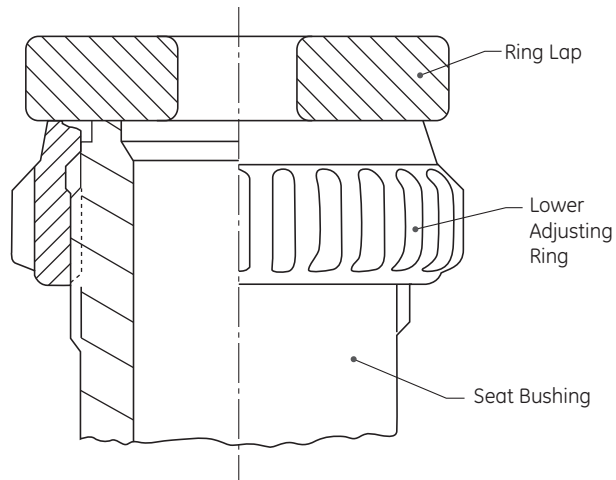

Figure 16: Bushing Seat Assembly

15. Next, remove both the lower adjusting ring pin and the lower adjusting ring from the valve base.

16. Normally the yoke rods do not have to be removed from the valve base. If however, it becomes necessary to remove them, the procedure below should be followed:

- a. Mark each rod relationship to where it contacts the valve base "ears", and also identifying which rod is to the right and which rod is to the left of the valve outlet.
- b. Loosen the yoke rod nuts using the appropriate size socket and handle.
- c. Remove the nuts, and then pull up on each rod to remove it from the base.

17. The valve is now ready to be cleaned and the parts inspected for proper size and condition.

XIII. Maintenance Instructions

A. General

It is not necessary to remove 1700 Series Maxiflow Safety Valves from the boiler for maintenance. The normal maintenance required is generally confined to touching up seats and occasionally replacing the disc.

The following tools are recommended for this work:

1. Flat lapping plate (Part No. 0439004).
2. Grinding compounds.
3. High temperature lubricant (Fel - Pro Nickel Ease).
4. Two (2) ring laps per valve size and type.

See Maintenance Tools and Supplies (Section XIX of this manual).

All of the above tools can be procured from GE, with prices being those that are in effect at the time of delivery. It may not be necessary to use all of the ring laps at any one time, but having a sufficient supply on hand will save the time of reconditioning them during a boiler outage. After the boiler is back on the line, the ring laps should be reconditioned on the flat lapping plate, or returned to the factory for reconditioning, at a nominal cost, on a special lapping machine. A lap should not be used on more than one valve without being reconditioned.

Valves that have been leaking should be disassembled in accordance with prior instructions. Since the position of the adjusting rings has been recorded, the rings can be removed for cleaning every time the valve is disassembled. Parts for each valve should be kept together or marked, to ensure that they are replaced in the same valve.

Reconditioning of the seat surface of the disc and seat bushing is accomplished by lapping with a flat cast iron, ring lap, as outlined in the lapping procedure. (See Section XIII.B.)

B. Lapping Procedure

1. General Information

While the finer points of lapping and “grinding-in” may be considered as a mechanical art, it is not beyond the ability of the average mechanic to produce good seats with some practice. No effort has been made in this manual to establish an exact procedure to cover each and every case, because different persons can get the same results using their own techniques.

The following precautions and hints will be of assistance when lapping nozzle and/or disc seats:

- a. Two (2) ring laps per valve.
- b. 1A Clover Grinding Compound per tool list. ⁽¹⁾
- c. 1000 Grit Kwik-Ak-Shun Grinding Compound per tool list. ⁽¹⁾
- d. Clean, lint free cotton rags.

⁽¹⁾ **This tool list is located in Section XIX.A of this manual.**

Before lapping the nozzle and disc seat, the leading edges (inside diameter of seats) of both must be slightly chamfered as follows:

Use a fine grade sandpaper to lightly break the inner edge and outer edge of the nozzle seat and disc seat. The purpose of this is to remove any small metal particles or fins attached to the sharp corner surfaces. Do not exceed .002” (0.05 mm) chamfer for this purpose.

2. To Lap The Bushing Seat

Note: If the bushing seat surface requires extensive lapping or reconditioning, a reseating machine should be used prior to lapping. (See “Reseating Machine,” in Section XIII.C of this manual.)

Cover the seat lap face with a light coating of 1A Clover Compound and gently place the lap on the valve bushing seat.

Note: A heavy coat of lapping compound tends to round off the edges of the seat.

Lap using an oscillating motion in various directions, while holding the lap loosely in the fingers and allowing the weight of the lap to rest on the seat surface. Control the motion of the lap to prevent either the inside or outside edge of the lap from crossing the bushing seat surface. If either edge touches the seat surface, the seat can become scratched and/or rounded.

XIII. Maintenance Instructions (Contd.)

Note: Care should be used not to run off the seating surface with the lap, as this will cause the seat to become uneven.

Do not lap excessively with a ring lap without resurfacing on a lapping plate as shown in Figure 17. Use a new ring lap, if further lapping is required, to remove any defect in the seat. To finish lapping the bushing seat, apply a light coating of #1000 Grit Compound to the face of the new lap, and repeat the above lapping motion.

Remove the ring lap and wipe the lap surface with a clean, lint free cloth, leaving compound on the bushing seat. Replace the ring lap on the seat and lap as above, but without adding compound. Repeat this operation until the seat has a mirror finish. Any evidence of defects, such as gray areas or scratches, will require a repeat of the whole lapping procedure until a mirror finish is attained.

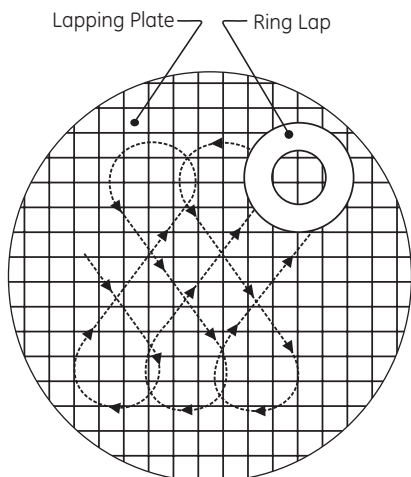

Figure 17: Ring Lap

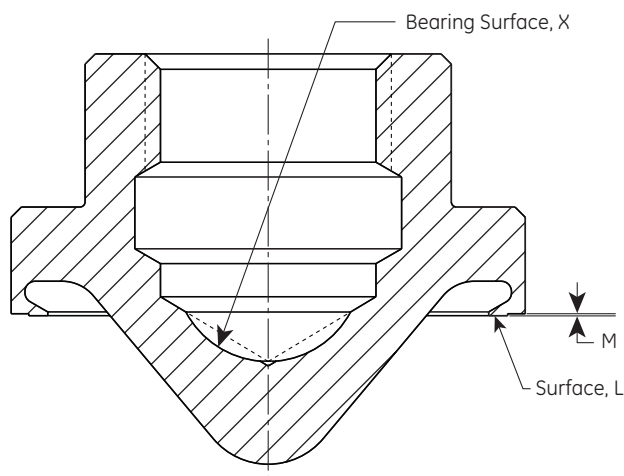

Figure 18: Thermoflex Disc

3. To Lap Disc Seat

The above lapping method is also used on the disc seat. When lapping the disc seat, the disc should be held stationary, but not rigidly, and the lap moved as above. Use care not to strike the cone of the disc, as this would cause the seat to be high on the inside.

The Thermoflex disc cannot be machined. If, after lapping, Dimension M, in Figure 18, does not meet the minimum specified in Table 2, the disc should be replaced.

It may not be necessary to use all the laps at any one time, but having a sufficient supply on hand will save reconditioning time. The laps should be reconditioned on the flat lapping plate, and a lap should not be used on more than one valve without being reconditioned. Laps must be checked for flatness prior to use, and at frequent intervals during use. A lap that is flat within one-half light band is considered satisfactory. Information on the Monochromatic Light and optical flat is available, upon request, from GE's Field Service department.

To recondition a ring lap, wipe all compound from the lapping plate and ring lap, then move the ring lap in a figure-eight motion on a lapping plate. If the lap is not flat, a shadow will be apparent. To remove the shadow, coat the lapping plate with 1000 Grit Compound and lap the ring, with figure-eight motions covering the lapping plate, as shown in Figure 17.

Table 2: Minimum Seat Relief		
Orifice	M min.	
	in.	mm
1	.004	0.10
2	.005	0.13
3	.006	0.15
5	.007	0.18
4	.008	0.20
6	.010	0.25
7_Q	.012	0.30
8	.012	0.30
R	.012	0.30
RR	.012	0.30

XIII. Maintenance Instructions (Contd.)

C. Reseating Machine Information

GE's Consolidated reseating machines should be used to recondition badly worn, out of tolerance, bushing seats. This machine can be provided by GE's Service department, and eliminates the need to remove a valve from the unit. The machine is mounted in place of the yoke and cuts the top face, inside diameter, and outside of the bushing, to establish the correct height, angles, and diameters. Replace the seat bushing if critical

dimensions D min. is exceeded. See Figures 19 & 20 and Table 4. Do not remove threads.

The use of the reseating machine is suggested for reconditioning badly worn seats, or for re-establishing critical dimensions (Figure 19). All the dimensions shown in Figure 19 should be re-established in accordance with the values in Table 3.

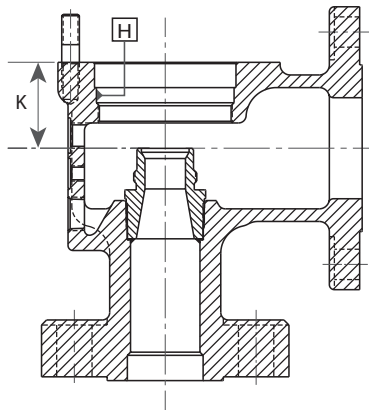

Figure 19: Base & Bush Assembly

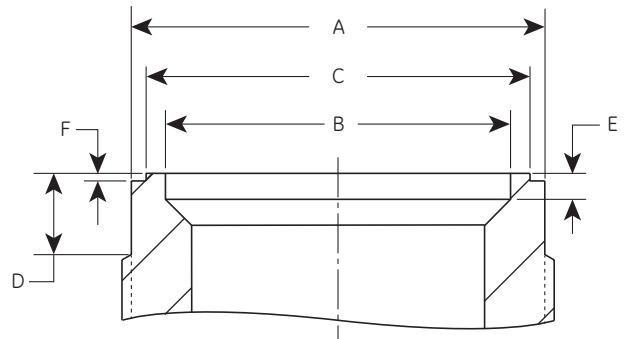

Figure 20: Seat Bushing Dimensions

Table 3: Seat Bushing Rework/Inspection Dimensions

Orifice	A + .002/- .003" (+0.05/-0.08 mm)		B max.		C ± .002" (±0.05 mm)		E ± .005" (±0.13 mm)		F ± .003" (±0.08 mm)	
	in.	mm	in.	mm	in.	mm	in.	mm	in.	mm
1	1.582	40.18	1.329	33.76	1.468	37.29	0.160	4.06	0.025	0.64
1 ⁽¹⁾	1.582	40.18	1.289	32.74	1.508	38.30	0.160	4.06	0.035	0.89
2	1.910	48.51	1.595	40.51	1.773	45.03	0.120	3.05	0.035	0.89
3	2.536	64.41	2.125	53.98	2.347	59.51	0.154	3.91	0.035	0.89
5	2.904 ⁽²⁾	73.76 ⁽²⁾	2.433	61.80	2.685	68.20	0.175	4.45	0.035	0.89
4	3.163	80.34	2.655	67.44	2.928	74.37	0.189	4.80	0.035	0.89
6	4.208	106.88	3.540	89.92	3.900	99.06	0.247	6.27	0.055	1.40
Q	4.988	126.70	4.424	112.37	4.873	123.77	0.304	7.72	0.055	1.40
8	5.944	150.98	5.013	127.33	5.523	140.28	0.343	8.71	0.055	1.40
R	6.314	160.38	5.324	135.23	5.876	149.25	0.364	9.25	0.055	1.40
RR	6.314	160.38	5.324	135.23	5.876	149.25	0.364	9.25	0.055	1.40

⁽¹⁾ Valve 1719, 1710 Only.

⁽²⁾ Tolerance: + .001" (0.03 mm)
- .002" (0.05 mm)

XIII. Maintenance Instructions (Contd.)

Table 4: Base/Seat Bushing Assembly Replacement Criteria											
Orifice	Valve Type	D min.		K max.		Orifice	Valve Type	D min.		K max.	
		in.	mm	in.	mm			in.	mm	in.	mm
1	1715	0.125	3.18	3.063	77.79	6	1765	0.313	7.95	4.750	120.65
	1716	0.125	3.18	3.063	77.79		1766	0.313	7.95	4.750	120.65
	1717	0.125	3.18	3.063	77.79		1767	0.500	12.70	4.766	121.06
	1719	0.125	3.18	3.813	96.84		1769	0.500	12.70	5.688	144.46
	1710	0.125	3.18	3.813	96.84		1760	0.500	12.70	6.760	171.70
	1713	0.250	6.35	3.813	96.84		Q (4")	1775Q	0.438	11.13	5.563
2	1725	0.203	5.16	3.813	96.84	1776Q	0.438	11.13	5.563	141.29	
	1726	0.203	5.16	3.813	96.84	Q (6")	1775Q	0.438	11.13	5.563	141.29
	1727	0.203	5.16	3.813	96.84	1776Q	0.438	11.13	5.563	141.29	
	1729	0.203	5.16	3.813	96.84	1777Q	0.438	11.13	5.563	141.29	
	1720	0.203	5.16	3.813	96.84	8	1785	0.438	11.13	5.563	141.29
	1723	0.312	7.92	4.313	109.54		1786	0.438	11.13	7.563	192.09
3	1735	0.250	6.35	4.875	123.83		1786-HP	0.438	11.13	7.563	192.09
	1736	0.250	6.35	4.875	123.83	1787	0.438	11.13	6.563	166.69	
	1737	0.250	6.35	4.875	123.83	R	1705R	0.438	11.13	5.563	141.29
	1739	0.250	6.35	5.688	144.46		1706R	0.438	11.13	5.563	141.29
	1730	0.250	6.35	5.688	144.46		1706R-HP	0.453	11.51	7.563	192.09
	1733	0.437	11.10	5.688	144.46		1707R	0.453	11.51	7.563	192.09
4	1755	0.313	7.95	5.688	144.46	RR	1705RR	0.438	11.13	5.563	141.29
	1756	0.313	7.95	5.688	144.46		1706RR	0.438	11.13	5.563	141.29
	1757	0.313	7.95	5.688	144.46		1706RR-HP	0.453	11.51	7.563	192.09
	1759	0.313	7.95	5.688	144.46		1707RR	0.453	11.51	7.563	192.09
	1750	0.313	7.95	5.688	144.46						
	1753	0.535	13.59	5.688	144.46						
5	1745	0.313	7.95	5.688	144.46						
	1746	0.313	7.95	5.688	144.46						
	1747	0.313	7.95	5.688	144.46						
	1749	0.313	7.95	5.688	144.46						
	1740	0.313	7.95	5.688	144.46						
	1743	0.535	13.59	5.688	144.46						

As a result of machining the bushing seat, the length of disc holder extending above the disc guide will decrease. Therefore, the top of the disc guide should be kept to a distance of at least .063" (1.59 mm), beneath the top of the disc holder, to facilitate freeing the disc holder, in case a deposit of dirt forms in the pocket between the two parts. This dimension is obtained by machining the top of the disc guide. (See Figure 21).

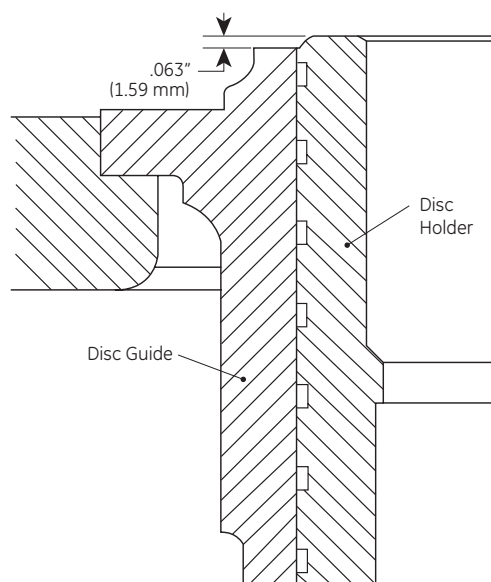

Figure 21: Guide - Disc Holder Assembly

XIII. Maintenance Instructions (Contd.)

D. Spindle Runout

It is important that the spindle be kept very straight in order to transmit the spring force to the disc without lateral binding. Overgagging is one of the common causes of bent spindles. A method to check the essential working surfaces of the spindle is illustrated in Figure 22. This may be performed either with or without the disc collar and lift stop on the spindle.

Using Figure 22 as a reference, clamp a V block (A) made of wood, fiber or other suitable material onto the platform railing. Imbed the ball end of the spindle in a piece of soft wood (B) and place the top of the spindle, below the threads, in the V block (A). Clamp a dial indicator onto the railing and locate at point (C). The total indicator reading should not exceed .007" (0.18 mm) when the spindle is rotated. If it does, the spindle must be straightened prior to reuse. To straighten the spindle, place the unthreaded portion of the small and large end in padded V blocks, with the point of maximum indicator readout upward, and then apply a downward force with a padded press or jack as required, until the spindle is within the specifications.

Other parts of the spindle not used as working surfaces may run out considerably more than .007" (0.18 mm), but this should not be regarded as unacceptable.

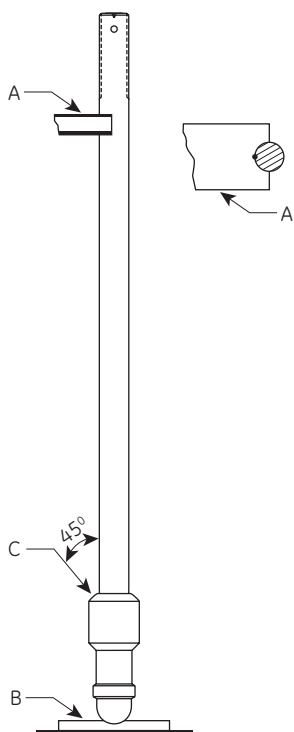

Figure 22: Spindle Check Stand

Although the upper thread end is not a working surface, excessive bending in this area could affect the accuracy of the Hydroset device and/or the EVT unit, if either of these devices is used to verify valve set pressure.

E. Disc Replacement and Disc-Spindle Bearing Requirements

To replace the disc, disassemble the valve in accordance with the instructions provided in Section XII of this manual.

Apply a small amount of lapping compound (1A) on the tip of the spindle. Install the disc, without the disc holder, onto the spindle tip, turning it clockwise until the disc threads drop out. Place a ring lap on a table, or similar flat surface, and wipe the exposed surface of the lap clean. Insert the disc nose into a ring lap, so that the seat contacts the lap surface. Oscillate the spindle using 360 degree oscillations for approximately 15 seconds, then check the spindle tip and disc "pocket" to determine progress (See Figure 23).

The spindle nose should be ground into the disc pocket until the bearing is clearly marked. The band position is shown in Figure 24.

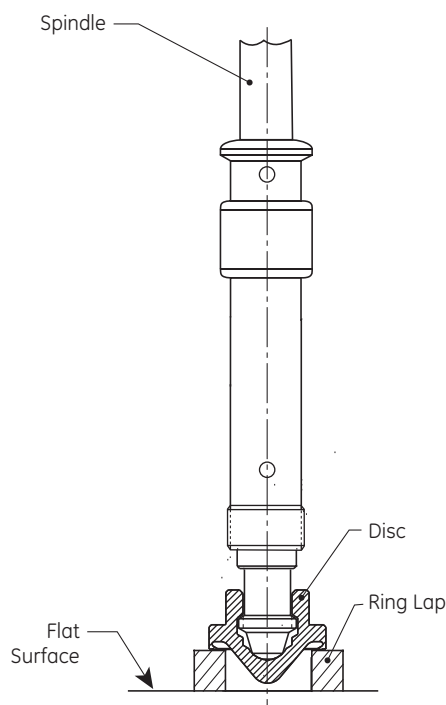

Figure 23: Disc - Spindle Bearing

XIII. Maintenance Instructions (Contd.)

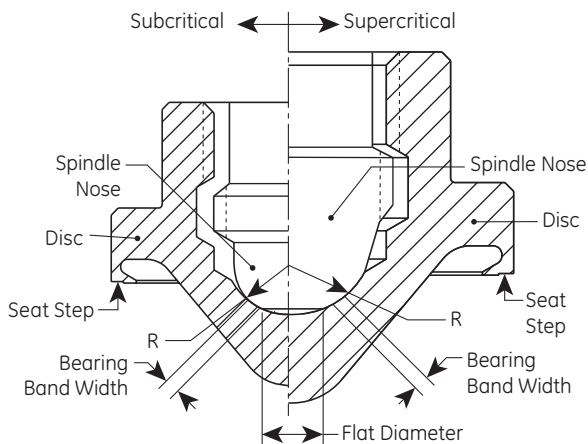

Figure 24: Disc - Spindle Assembly

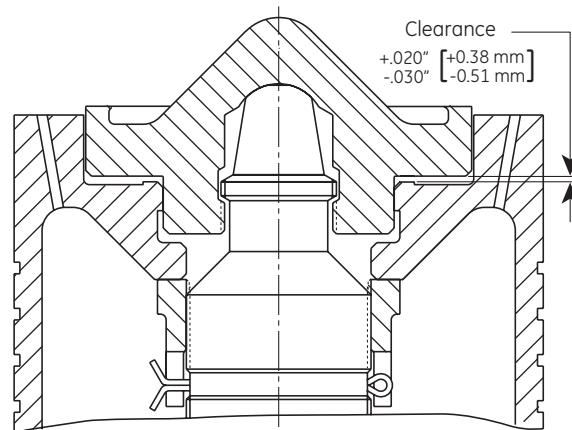

Figure 25: Disc Rock

Table 4a: Grinding Characteristics of Disc Pocket Steam Service Subcritical

Orifice	Pressure Class: 600, 900, 1500, 2500, 3000					
	Nose Radius R + .003"/-0.002" (+0.08/-0.05 mm)		Flat Diameter		Bearing Band Width	
	in.	mm	in.	mm	in.	mm
1	0.275 ⁽¹⁾	6.99 ⁽²⁾	0.125	3.18	0.125	3.18
2	0.369 ⁽¹⁾	9.37 ⁽²⁾	0.188	3.18	0.125	3.18
3	0.495	12.50	0.250	6.35	0.219	5.56
5	0.495	12.50	0.250	6.35	0.219	5.56
4	0.495	12.50	0.250	6.35	0.219	5.56
6	0.495	12.50	0.250	6.35	0.219	5.56
Q	0.682	17.27	0.250	6.35	0.281	5.56
8	0.713	18.03	0.313	7.95	0.313	7.95
R	0.713	18.03	0.313	7.95	0.313	7.95
RR	0.713	18.03	0.313	7.95	0.313	7.95

⁽¹⁾ +/- 0.002

⁽²⁾ +/- 0.05

The desired band width for subcritical valves is shown in Table 4a, and the desired band width for supercritical valves is shown in Table 5. In addition, the finished machine size of the spindle nose radius, and the flat diameter for each orifice size and valve type are also shown in these two (2) tables.

If the required bearing band cannot be obtained by hand grinding, then this radius should be checked and remachined if necessary.

If the band extends too high on the radius it will be difficult to rock the disc, and the disc may lock up under

Table 5: Grinding Characteristics of Disc Pocket Steam Service Supercritical

Orifice	Pressure Class: 4500					
	Nose Radius R + .003"/-0.002" (+0.08/-0.05 mm)		Flat Diameter		Bearing Band Width	
	in.	mm	in.	mm	in.	mm
1	0.369 ⁽¹⁾	9.37 ⁽²⁾	0.188	4.78	0.156	3.96
2	0.369 ⁽¹⁾	9.37 ⁽²⁾	0.188	4.78	0.156	3.96
3	0.492	12.50	0.250	6.35	0.219	5.56
5	0.492	12.50	0.250	6.35	0.219	5.56
4	0.492	12.50	0.250	6.35	0.219	5.56

⁽¹⁾ +/- 0.002

⁽²⁾ +/- 0.05

pressure. If the band is too narrow, the spindle may indent the disc and again the rock will be lost.

When the bearing area is re-established, clean both surfaces. Then apply lubricant to the spherical surface of the spindle tip, and work it into the surfaces by rotating the disc on the spindle.

Place the disc holder on the spindle, allowing it to rest on the face of the disc collar as previously shown in Figure 12 on Section XII.B. Then assemble the disc holder and new disc. The disc should be free enough to rock on the spindle tip. If there is no freedom, lower the disc collar until the disc is free to rock slightly initially, approximately .001 to .002 inches (0.25 to 0.05 mm) rock. The disc collar must then be lowered two additional notches from this initial position and secured with a stainless steel cotter pin. (See Figure 25).

Note: Failure to provide the recommended disc rock at assembly will result in a leaking valve.

XIII. Maintenance Instructions (Contd.)

F. Grinding the Compression Screw

Some valve designs feature a compression screw with a spherical radius tip as shown in Figure 26. For these designs, the compression screw spherical bearing surface must be ground into the upper washer so that full contact along the spherical radius is obtained. To grind these items, a 320 grit (Clover 1A) lapping compound is used for roughing-in and then finish lap with 1000 Grit Kwik-Ak-Shun lapping compound until a satisfactory bearing band is obtained. Clean the compression screw, and upper spring washer when completed.

G. Thrust Bearing Surfaces

For those designs utilizing a ball-type thrust bearing, the aligning washer must match evenly to the lower thrust bearing spherical surface, such that full face contact is achieved between the parts (see Figure 27). Therefore, grind together, or replace the entire thrust bearing, as necessary.

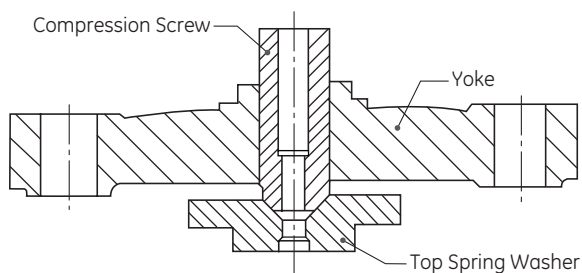

Figure 26: Compression Screw Assembly

H. Grinding The Lower Spring Washer

The lower spring washer bearing surface must be ground to the spindle. To grind the lower spring washer, a 320 grit (Clover 1A) lapping compound is used for roughing-in, and then finish lap with 1000 Grit Kwik-Ak-Shun lapping compound until a satisfactory bearing band is obtained. The bearing width should be .125" (3.2 mm) min. to .063" (4.8 mm) max. Clean the lower spring washer and spindle when complete.

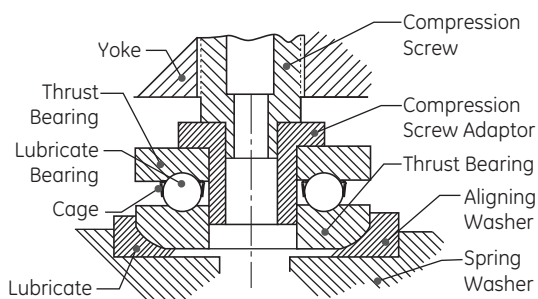

Figure 27: Thrust Bearing Assembly

XIV. Inspection and Part Replacement

A. General Information

Once the valve is disassembled, the appropriate parts can be inspected for damage and their suitability for reuse.

B. Specific Steps

As a minimum, the following parts should be inspected as specified below:

Table 6: Allowable Guide/Disc Holder Clearance															
Orifice	Valve Type (Temp. Class)	Maximum Clearance				Orifice	Valve Type (Temp. Class)	Maximum Clearance							
		B Temp.		D-H Temp.				B Temp.		D-H Temp.					
		in.	mm	in.	mm			in.	mm	in.	mm				
1	1715	0.005	0.13	0.008	0.20	6	1765	0.014	0.36	0.014	0.36				
	1716						1766								
	1717						1767								
	1719						1769								
	1710						1760								
	1713														
2	1725	0.008	0.20	0.012	0.30	Q (4" & 6") (101.6 & 152.4 mm)	1775Q	0.025	0.64	0.025	0.64				
	1726					1776Q									
	1727					1777Q									
	1729					8	1785	0.027	0.69	0.027	0.69				
	1720						1786								
	1723						1786-HP								
	1787														
3	1735	0.008	0.20	.013	0.33	R	1705R (B)	0.020	0.51	-	-				
	1736						1705R (D-H)	-	-	0.028	0.71				
	1737						1706R (B)	0.020	0.51	-	-				
	1739	1706R (D-H)	-	-	0.028		0.71								
	1730	0.010	0.25	.015	0.38		1706R-HP	0.020	0.51	0.020	0.51				
	1733						1707R	0.020	0.51	0.020	0.51				
5	1755	0.011	0.28	0.017	0.43	RR	1705RR	0.020	0.51	0.020	0.51				
	1756						1706RR (B)	0.020	0.51	0.028	0.71				
	1757						1706RR (D-H)	-	-	0.028	0.71				
	1759						1706RR-HP	0.020	0.51	0.020	0.51				
	1750						0.020	0.51	0.020	0.51	1707RR	0.020	0.51	0.020	0.51
	1753														
4	1745	0.012	0.30	.018	0.46										
	1746														
	1747														
	1749														
	1740														
	1743														

XIV. Inspection and Part Replacement (Contd.)

1. Disc Holder

The surface on the end of the disc holder closest to the disc must be free from steam erosion. The two small holes must be open to ensure the passage of steam to the chamber above the disc. Make sure the outside diameter is not egg shaped and the surface is smooth. If any small indication of galling is present, polish the high spots with an emery cloth. If serious or large scale galling is present, the disc holder should be replaced.

2. Guide

Inspect the guide inside diameter for egging, and ensure the inside surface is smooth. The threads on the outside must be in good condition to ensure the upper ring will adjust, even when the valve is hot. If serious or large scale galling is present, the guide should be replaced.

3. Clearance

The maximum clearance between the disc holder and guide should be in accordance with Table 6.

4. Disc

Inspect the disc seat for steam cuts, nicks, or other damage. If the seat step measures less than dimensions specified in Table 2, this indicates that the thermal lip has been lapped to the minimum thickness.

Do not machine any Thermoflex disc; however, a disc which is not below minimum relief can be lapped to remove minor damage (See Figure 18, on Section XIII.B.)

5. Overlap Collar

Inspect the outside diameter for nicks, burrs, tears, pitting and signs of galling. Then, inspect the lugs for galling, tearing, and damage.

6. Coverplate

Ensure that the floating washers are free to move and are not bent or deformed. Check the surface of the inside diameter on the floating washers and the washer retainers for tears, pitting, corrosion, and signs of galling. Ensure that the bleed hole in the coverplate is not obstructed.

XV. Re-Assembly of 1700 Series Safety Valve

A. General Information

The Type 1700 Safety Valve can be easily re-assembled after required inspection/maintenance of internal parts has been performed. (Again, refer to Figures 1 to 5 for parts nomenclature.) All parts should be clean prior to assembly. See Section XIX for recommended compounds, lubricants, and tools.

B. Specific Steps

1. If they have been removed, the yoke rods are installed into the base, and then the yoke rod nuts installed. Locate the yoke rods in the original location in the valve base as recorded during disassembly. Lubricate all threads. Yoke rod nuts are then to be torqued using the yoke rod nut torque wrench and socket. Torque nuts in accordance with Table 7.

Note: Use of an impact device to produce required torque values is not recommended.

2. Prior to reinstalling the lower adjusting ring, lubricate the threads of the lower adjusting ring pin and partially insert the pin into the valve body. Now the pin can again serve as a "pointer," or reference point, as previously described in Section

XII.B.14 of "Disassembly." Next lubricate the threads of the lower adjusting ring, and install the ring in the valve body. Then, turn the lower adjusting ring clockwise until the top of the ring clears the seat.

3. To position the lower adjusting ring, place a clean ring lap on the nozzle seat and move the lower adjusting ring up until it makes contact with the ring lap. If the original location of the adjusting ring was recorded, simply lower the ring, by moving it down, the same number of notches as was recorded in Step XII.B.12 of "Disassembly." If information on the original lower ring position

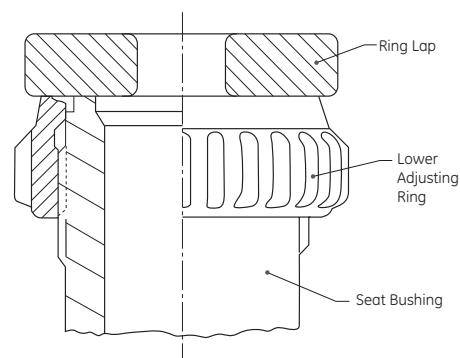

Figure 28: Bushing Seat Assembly

XV. Re-Assembly of 1700 Series Safety Valve (Contd.)

Table 7: Yoke Rod Nuts Torque Specification

Valve Type	Torque				Valve Type	Torque			
	min.		max.			min.		max.	
	ft-lbs	Nm	ft-lbs	Nm		ft-lbs	Nm	ft-lbs	Nm
1710	150	203	200	271	1755	315	427	415	563
1713	230	312	500	678	1756	315	427	415	563
1715	150	203	195	264	1757	315	427	415	563
1716	150	203	195	264	1759	350	475	450	610
1717	150	203	195	264	1760	1200	1627	1750	2373
1719	150	203	200	271	1765	315	427	415	563
1720	185	251	285	386	1766	315	427	415	563
1723	315	427	415	563	1767	315	427	415	563
1725	160	217	250	339	1769	315	427	415	563
1726	150	203	200	271	1775	550	746	700	949
1727	150	203	200	271	1776	400	542	500	678
1729	185	251	285	386	1775Q	550	746	700	949
1730	315	427	415	563	1776Q	400	542	500	678
1733	350	475	450	610	1777Q	550	746	700	949
1735	300	407	375	508	1785	550	746	700	949
1736	165	224	250	339	1786	550	746	700	949
1737	165	224	250	339	1786-HP	850	1152	1100	1491
1739	315	427	415	563	1787	850	1152	1100	1491
1740	350	475	450	610	1705R	550	746	700	949
1743	850	1152	1100	1491	1706R	550	746	700	949
1745	315	427	415	563	1706R-HP	850	1152	1100	1491
1746	315	427	415	563	1707R	850	1152	1100	1491
1747	315	427	415	563	1705RR	550	746	700	949
1749	350	475	450	610	1706RR	550	746	700	949
1750	350	475	450	610	1706RR-HP	850	1152	1100	1491
1753	850	1152	1100	1491	1707RR	850	1152	1100	1491

is not available, the ring should be lowered, by moving it down one notch for every 600 psig (20.7 barg) of set pressure.

Note: For a valve set pressure of 1200 psig (81.6 barg), the ring will have to be lowered two (2) notches below the bushing seat. This will be the starting position, with the final position being determined during field testing (See Figure 28).

- Once the lower adjusting ring is in its correct location, lock it in place by screwing in the lower adjusting ring pin. Verify that the lower ring is capable of a slight movement. If the lower ring does not move, the pin is too long. Should this be

the case, grind the end of the pin slightly to shorten it, while retaining the original tip contour, then reinstall the pin.

- If the upper adjusting ring has been removed from the guide, lubricate the ring threads and re-install the ring on the guide.
- Install the adjusting ring and guide assembly into the valve base such that the scribe marks will be visible from the valve outlet or an inspection port. Place a scale or other suitable thin flat metal object on the lower face of the upper adjusting ring and measure the overall length of the upper ring and guide assembly. Adjust the upper ring to the

XV. Re-Assembly of 1700 Series Safety Valve (Contd.)

Dimension C (See Figure 29) recorded in Step 12 of Section XII.B., "Disassembly". Observe the marks made on the ring and guide and adjust the ring to align the marks (see Figure 30.) Recheck the overall length of the adjusting ring and guide assembly to assure that the upper ring is in its original position.

7. Measure from the top of the guide to the bushing seat with a depth micrometer. Subtract Dimension B as measured in Step 12, Section XII.B., "Disassembly," from the dimension previously measured. The difference is the distance the upper adjusting ring must be lowered. Refer to Table 8 and 9, to determine the number of notches that the ring is to be lowered.
8. Once certain that the upper adjusting ring/guide assembly is properly set, lubricate the guide seating surface in the valve base, and reinstall the assembly into the base; then, lubricate the threads of the upper adjusting ring pin, and lock the ring/guide assembly in place by screwing in the pin. Verify that the upper ring is capable of a slight movement. If the upper ring does not move, the pin is too long. Should this be the case, grind the end of the pin to shorten it, while retaining the original tip contour, then reinstall the pin.
9. Clamp the spindle in a padded vise, with the "ball end" of the spindle upward.
10. Verify that the spindle bearing has been ground to the disc pocket, as specified in Section XVI.E, "Disc Replacement and Disc Spindle Bearing Requirements," of this manual.
11. If the lift stop was removed from the spindle, lubricate the threads and install the lift stop. Do not install the cotter pin at this time.
12. If the disc collar was removed, lubricate the threads and install on the spindle. Do not install the cotter pin at this time. Then, carefully lower the disc holder onto the spindle, allowing it to sit on the face of the disc collar.
13. Thread the disc onto the spindle, ensuring that the disc is free to "rock" on the spindle tip as specified in Section XIII.E., "Disc Replacement and Disc Spindle Bearing Requirements," of this manual. If disc "rock" is not satisfactory, correct the cause before proceeding. When disc "rock" is satisfactory, remove the disc and disc holder, and secure the disc collar with a stainless steel cotter pin. Using side cutters, carefully cut off excess cotter pin legs, and bend the cotter pin for a neat installation.
14. Lubricate the spindle tip, and assemble the disc holder and disc to spindle. Recheck the rock.
15. Remove complete assembly from the vise, being sure to protect the disc seat surface at all times.
16. Prior to installing the spindle assembly into the valve base, wipe the disc seat with a soft, lint-free cloth. Then, carefully install the spindle assembly into the guide.
17. Install the coverplate over the spindle assembly, ensuring that the coverplate is correctly oriented with regard to the valve base, as previously marked for this purpose during disassembly (See Step XII.B.9.) Then, install the coverplate nuts, with the nuts being only hand tightened.

Note: This step must be accomplished before proceeding with reassembly.

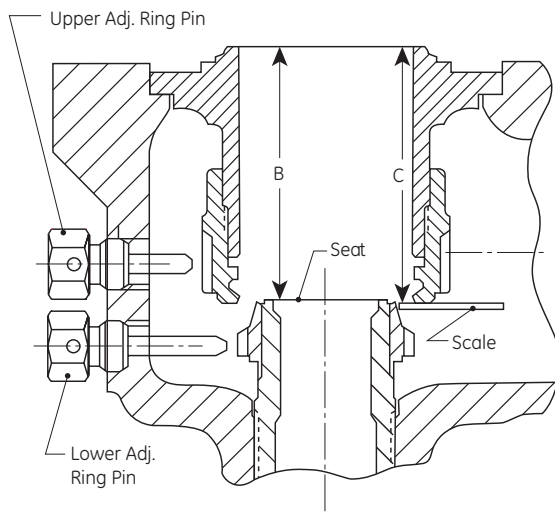

Figure 29: Guide - Bushing Seat Assembly

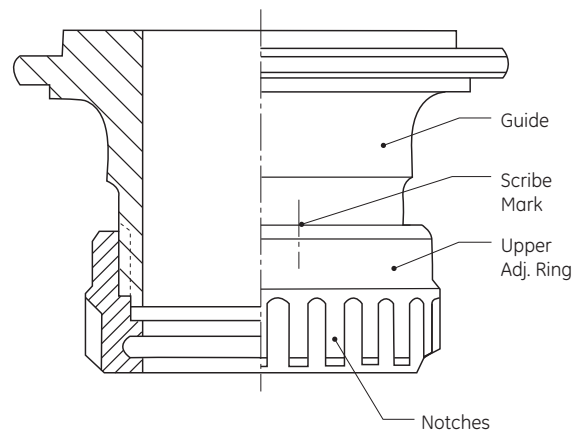

Figure 30: Upper Adj. Ring - Guide Assembly

XV. Re-Assembly of 1700 Series Safety Valve (Contd.)

Table 8: Adjusting Ring Presetting Information

Orifice	Orifice Area		Set Pressure Range ⁶				Lower Ring Position ^(1,4)	Saturated Steam (Temp. Class B)		Superheated Steam (Temp. Class D, E, F, G, H)		Overlap Collar Position ^{2,3}	
			min.		max.			Upper Ring (Seat) ⁽⁴⁾	Upper Ring (Disc Holder) ⁽⁵⁾	Upper Ring (Seat) ⁽⁴⁾	Upper Ring (Disc Holder) ⁽⁵⁾	Std. Lift	Rest. Lift
	in ⁽²⁾	cm ⁽²⁾	psig	barg	psig	barg							
#1	0.994	6.413	80	5.52	300	20.68	2N (up) 1N down per 600 psig. Maximum 5N down	15N (down)	25N (down)	Seat Level	10N (down)	6N (down)	3N (down)
			301	20.75	500	34.47		20N (up)	10N (up)	Seat Level	10N (down)		
			501	34.54	900	62.05		20N (up)	10N (up)	Seat Level	10N (down)		
			901	62.12	1500	103.42		15N (up)	5N (up)	5N (down)	15N (down)		
			1501	103.49	2500	172.37		10N (up)	3N (down)	10N (down)	23N (down)		
			2501	172.44	2800	193.05		10N (up)	3N (down)	10N (down)	23N (down)		
			2801	193.12	3000	206.84		5N (up)	8N (down)	15N (down)	28N (down)		
#2	1.431	9.232	101	6.96	300	20.68	1N down per 600 psig. Maximum 5N down	20N (up)	8N (up)	Seat Level	12N (down)	7N (down)	3N (down)
			301	20.75	500	34.47		20N (up)	8N (up)	Seat Level	12N (down)		
			501	34.54	900	62.05		20N (up)	8N (up)	Seat Level	12N (down)		
			901	62.12	1500	103.42		15N (up)	3N (up)	5N (down)	17N (down)		
			1501	103.49	2500	172.37		10N (up)	Disc Holder Level	10N (down)	22N (down)		
			2501	172.44	2800	193.05		10N (up)	Disc Holder Level	10N (down)	22N (down)		
			2801	193.12	3000	206.84		5N (up)	7N (down)	15N (down)	27N (down)		
#3	2.545	16.419	101	6.96	300	20.68	1N down per 600 psig. Maximum 5N down	25N (up)	9N (up)	Seat Level	16N (down)	8N (down)	4N (down)
			301	20.75	500	34.47		25N (up)	9N (up)	Seat Level	16N (down)		
			501	34.54	900	62.05		25N (up)	9N (up)	Seat Level	16N (down)		
			901	62.12	1500	103.42		20N (up)	4N (up)	10N (down)	26N (down)		
			1501	103.49	2500	172.37		15N (up)	Disc Holder Level	20N (down)	36N (down)		
			2501	172.44	2800	193.05		15N (up)	Disc Holder Level	20N (down)	36N (down)		
			2801	193.12	3000	206.84		15N (up)	Disc Holder Level	20N (down)	36N (down)		
#4	3.341	21.555	101	6.96	300	20.68	1N down per 600 psig. Maximum 5N down	50N (up)	34N (up)	Seat Level	16N (down)	10N (down)	5N (down)
			301	20.75	500	34.47		50N (up)	34N (up)	Seat Level	16N (down)		
			601	34.54	900	62.05		40N (up)	24N (up)	10N (down)	26N (down)		
			901	62.12	1500	103.42		40N (up)	24N (up)	10N (down)	26N (down)		
			1501	103.49	2500	172.37		40N (up)	24N (up)	15N (down)	31N (down)		
			2501	172.44	2800	193.05		45N (up)	29N (up)	25N (down)	41N (down)		
			2801	193.12	3000	206.84		45N (up)	29N (up)	25N (down)	41N (down)		
#5	3.976	25.652	101	6.96	300	20.68	1N down per 600 psig. Maximum 5N down	55N (up)	38N (up)	Seat Level	17N (down)	9N (down)	4N (down)
			301	20.75	500	34.47		55N (up)	38N (up)	Seat Level	17N (down)		
			501	34.54	900	62.05		50N (up)	33N (up)	10N (down)	27N (down)		
			901	62.12	1500	103.42		45N (up)	28N (up)	15N (down)	32N (down)		
			1501	103.49	2500	172.37		45N (up)	28N (up)	20N (down)	37N (down)		
			2501	172.44	2800	193.05		45N (up)	28N (up)	25N (down)	42N (down)		
			2801	193.12	3000	206.84		45N (up)	28N (up)	25N (down)	41N (down)		
#6	7.070	45.613	101	6.96	300	20.68	1N down per 600 psig. Maximum 5N down	Seat Level	45N (down)	Seat Level	45N (down)	13N (down)	6N (down)
			301	20.75	500	34.47		70N (up)	25N (up)	Seat Level	45N (down)		
			501	34.54	900	62.05		65N (up)	20N (up)	10N (down)	55N (down)		
			901	62.12	1100	75.84		60N (up)	15N (up)	20N (down)	65N (down)		
6"-Q	11.050	71.290	All Pressures				1N down per 600 psig. Maximum 3N down	Seat Level	45N (down)	½ Turn Below Seat Level	81N (down)	16N (down)	8N (down)
4"-Q	12.250	79.032										20N (down)	10N (down)
#8	14.180	91.484											
R	16.000	103.226											
RR	19.290	124.451											

⁽¹⁾ If valve is to be tested on superheated steam, set lower ring at seat level.
⁽²⁾ Set notches down from the point the lowest scribe line is level with the top floating washer.
⁽³⁾ All overlap collar adjustments are down from this bottom scribe mark.
⁽⁴⁾ Position reference to seat level
⁽⁵⁾ Position reference to the bottom of disc holder.
⁽⁶⁾ For pressures over those listed in this table, use the same ring setting as the highest listed pressures.

XV. Re-Assembly of 1700 Series Safety Valve (Contd.)

Orifice	Pressure Class	Total Number of Notches		Number of Notches Disc Holder to Seat		Distance Traveled per Notch			
		Lower Ring	Upper Ring	Lower Ring	Upper Ring	Lower Ring		Upper Ring	
						in.	mm	in.	mm
#1	600 - 1500	18	22	7	10	.004	0.09	.003	0.06
	2000 - 4500		28		13	.004	0.09	.002	0.05
#2	All	21	31	8	12	.003	0.08	.002	0.05
#3	All	31	41	12	16	.002	0.05	.002	0.04
#5	All	31	37	12	17	.002	0.05	.002	0.04
#4	All	31	47	12	16	.002	0.05	.002	0.04
#6	600 - 1500	41	56	30	45	.002	0.04	.001	0.03
	2000 - 3000				40	.002	0.04	.001	0.03
Q	All	48	62	30	45	.002	0.04	.001	0.03
#8	All	50	83	36	45	.001	0.03	.001	0.03
R, RR	All	50	83	32	45	.001	0.04	.001	0.03

18. Next, install the yoke and compression screw assembly over the yoke rods and spindle.
19. Next, refer to Figure 31 and establish Dimension A.
20. Pull up on the spindle until the lift stop contacts the coverplate and repeat the measurement of Dimension A, while the lift stop and coverplate are in contact. The difference between these two measurements is the valve lift. The valve lift should be equal to the nameplate lift, plus the additional recommended lift as shown in Table 10.

Note: Do not deviate from stamped nameplate lift.

21. If the measured dimension is:

a. Correct:

1. Remove the yoke and coverplate.
2. If the cotter pin has been removed from the lift stop, lift the spindle assembly from the valve and disassemble it.
3. Install the lift stop cotter pin, re-assemble the spindle assembly, and re-install the spindle assembly into the valve guide.
4. Install the coverplate and torque coverplate nuts to the correct values per stud size. Stud size .500" (12.70 mm), torque 30 ft-lbs (40.67 Nm). Stud size .625" (15.88 mm), torque 60 ft-lbs (81.35 Nm). Stud size .750" (19.50 mm), torque 100 ft-lbs (135.58 Nm). (Do not re-install yoke at this time.)

b. Incorrect:

1. Remove yoke and coverplate.
2. Adjust valve lift, as required, in the following manner:
 - a. Increase valve lift by moving the lift stop down one (1) notch for each .010" (0.25 mm) increase required.
 - b. Decrease valve lift by moving the lift stop up one (1) notch for each .010" (0.25 mm) decrease required.

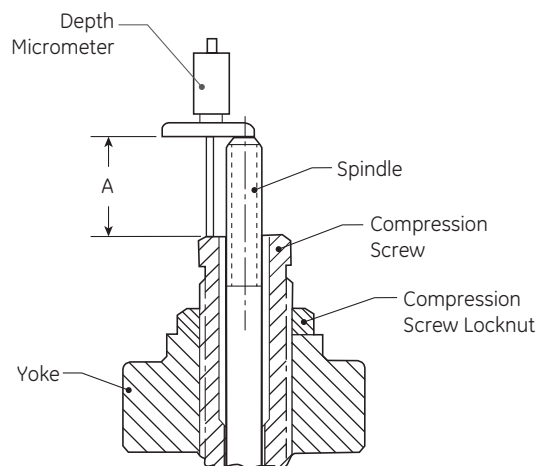

Figure 31: Yoke-Spindle Assembly

XV. Re-Assembly of 1700 Series Safety Valve (Contd.)

Table 10: Required Minimum Lift										
Orifice Designation	Minimum Certified Lift		Additional Recommended Lift ⁽¹⁾							
			Temperature Class							
			A		B		C		D, E, F, G, H	
	in.	mm	in.	mm	in.	mm	in.	mm	in.	mm
1	0.281	7.14	0.020	0.51	0.020	0.51	0.030	0.76	0.030	0.76
2	0.338	8.59	0.030	0.76	0.030	0.76	0.040	1.02	0.040	1.02
3	0.450	11.43	0.030	0.76	0.030	0.76	0.040	1.02	0.040	1.02
5	0.516	13.11	0.030	0.76	0.030	0.76	0.040	1.02	0.040	1.02
4	0.563	14.30	0.030	0.76	0.030	0.76	0.040	1.02	0.040	1.02
6	0.750	19.05	0.030	0.76	0.030	0.76	0.040	1.02	0.050	1.27
7	0.938	23.83	0.030	0.76	0.040	1.02	0.050	1.27	0.050	1.27
1775Q/1776Q	0.987	25.07	0.030	0.76	0.040	1.02	0.050	1.27	0.050	1.27
1775Q/1776Q	0.938	23.83	0.030	0.76	0.040	1.02	0.050	1.27	0.050	1.27
1777Q	0.938	23.83	0.040	1.02	0.050	1.27	0.050	1.27	0.060	1.52
8	1.063	27.00	0.040	1.02	0.050	1.27	0.050	1.27	0.060	1.52
R	1.129	28.68	0.050	1.27	0.050	1.27	0.060	1.52	0.070	1.78
1705RR/1706RR	1.240	31.50	0.040	1.02	0.050	1.27	0.050	1.27	0.060	1.52
1707RR	1.240	31.50	0.050	1.27	0.050	1.27	0.060	1.52	0.070	1.78

⁽¹⁾ Total lift tolerance is +.020"/-.000" (+0.51/-0.00 mm). Per ASME Section I Code, the valve lift must be mechanically verified and shall meet or exceed the required lift.

22. Verify that the valve lift is now correct by repeating Steps 17 through 21. If the lift is correct, proceed to Step 21.a. If the lift is incorrect, repeat Step 21.b.
23. If the overlap collar has been removed from the spindle, lubricate the collar threads and place over the spindle with the notches in the collar up (i.e., away from the coverplate). Note that the overlap collar has four circumferential scribe lines. The lower scribe line is the one farthest away from the notches. (See Figure 32.) Thread the overlap collar onto the spindle by turning in a clockwise direction, until the lower scribe line is even with the visible floating washer. Align the nearest overlap collar notch with the drilled hole in the spindle by moving the overlap collar down.
24. Refer to Table 11 before making the initial overlap collar adjustment.

Note: These adjustments differ for each orifice size. (Also note that restricted lift valves require a different overlap collar adjustment).

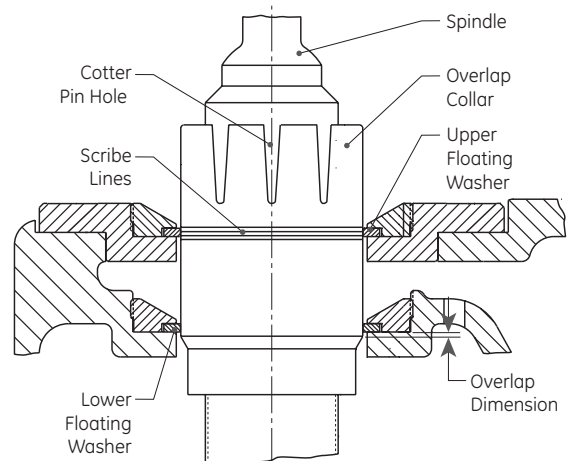

Figure 32: Collar and Spindle Assembly

XV. Re-Assembly of 1700 Series Safety Valve (Contd.)

25. To adjust the overlap collar, move the collar down the number of notches specified in Table 11 or, if the original setting is to be re-established, reset the collar to the position previously recorded during disassembly. (See Section XII.B.8.)
26. Install cotter pin through overlap collar notches and spindle. Trim cotter pin to proper length, and bend the ends to secure the overlap collar and spindle together.
27. Before installing the spring washer, lubricate the bearing surfaces on lower spring washer and the spindle. Then, install lower spring washer onto the spindle.
28. Determine which end of the spring is to be fitted to the lower spring washer as determined in the disassembly procedure. (See Section XII.B.7.) Lower the spring gently over the spindle until it is seated on lower spring washer. Install the top spring washer onto the spring, and insure that the lug engages the left yoke rod when facing in the same direction as the outlet.
29. If compression screw has been removed, lubricate the threads of the compression screw and yoke. Install the lock nut onto the compression screw and thread the compression screw into yoke, until the screw is just protruding from lower end of the yoke.

Note: If the valve utilizes a bearing with a compression screw adaptor as shown in Figure 26 (Section XIII.F), install the adaptor onto the top spring washer. Install the bottom race and pack the thrust bearing with lubricant, then install the bearing and the top race into the adaptor.

30. Lubricate upper yoke rod threads. Carefully position the yoke assembly over the yoke rods taking care to align the compression screw with either the bearing or upper spring washer as applicable.
31. Using the yoke rod nut torque wrench and the socket, torque the yoke rod nuts as specified in Table 7.
32. Next, return the compression screw to its original position recorded during disassembly (see Section XII.B.4), and tighten compression screw lock nut.
33. Ensure that the top washer lug does not remain in

Table 11: Overlap Collar Adjustment				
Orifices	Bore Diameter		Adjustment Notches	
	In	mm	Standard	Restricted Lift
1	1.250	31.75	6	3
2	1.350	34.29	7	3
3	1.800	45.72	8	4
5	2.062	52.37	9	4
4	2.250	57.15	10	5
6	3.000	76.20	13	6
7	3.750	95.25	16	8
Q	3.984	101.19	16	8
8	4.250	107.95	18	9
R	4.515	114.68	20	10

contact with the yoke rod, after final compression screw adjustment.

34. Install the release nut onto the spindle and thread clockwise, until the release nut is fully engaged on the spindle thread.
35. Install the cap over the release nut, and seat the cap firmly into place on the yoke. Install the top lever in the cap and, then, insert the lever pin through the top lever and cap holes.
36. Adjust the release nut, until it clears top lever by .125" (3.18 mm). Remove the lever pin, top lever, and cap. Next, insert a cotter pin through the release nut slots and spindle, and spread cotter pin ends. (If spindle has been replaced, a cotter pin hole must be drilled through the replacement spindle.) Re-assemble the cap with the drop lever, top lever, and top lever pin. Install a cotter pin to lock the top pin in place. A final check should be made to ensure the proper clearance exists between the release nut and the top lever. Finally, tighten cap set screw to secure the cap.

XVI. Setting and Testing

A. Field Testing

A.1 General Information

All 1700 Series Maxiflow safety valves are steam tested at the factory to verify set pressure adjustability and seat tightness. Every valve is set to have a clean popping action and to reseal tightly. However, because the boiler used in setting the valves has a small capacity, compared to the capacities of the Maxiflow type of valves, adjustments on the actual installation are necessary to ensure proper valve action and “adjusting ring” settings. When supplied for pressures over 2500 psig (172.37 barg), the compression screw lock nut will be locked to the compression screw with a 1/4-20 Allen screw, in order to locate the exact amount of compression screw engagement in the valve yoke. The compression screw has then been backed out to decrease the spring load on the seat by 75%. See Red Letter Warning Tag, attached to compression screw of each Maxiflow valve by means of double strand sealing wire, which reads as follows:

WARNING
<p>This valve has been steam tested and set to the proper set pressure; however the compression on the spring has been relaxed by backing out the compression screw.</p> <p>Before the hydrostatic test on the boiler the compression screw must be turned clockwise until the lock nut makes up on the yoke .</p> <p>Remove the 1/4-20 Allen screw to allow the lock nut to turn on compression screw for future adjustments.</p> <p>(Note attached tag for hydrostatic plug removal).⁽¹⁾</p>

⁽¹⁾ **The parenthetical statement is a reference to the tag shown in Figure 36 in Section XVIII.A.**

Upon completion of hydrostatic testing of the boiler, but prior to placing the boiler in service, ensure that the hydrostatic plugs are removed from all valves (**Note:** See Figure 6 in Section X: Operating Principles of this manual). The use of Consolidated Hydroset or EVT, units can serve to establish set pressure but cannot be used for verifying blowdown, lift, etc (For additional information, see Section XVI.A5.) Gaging of other valves not being set will not generally be necessary; however, for setting of high pressure valves, depending on system pressure being used, it may be necessary to gag the lower set valves.

Boiler safety valve tests can be conducted with the unit either on or off the line. However, with the unit on the line under full load, a sudden load drop could be dangerous as most of the safety valves will be gagged. Therefore, it is recommended that the safety valves be tested and adjusted with the boiler isolated, or with light load. Boiler control can then be maintained, with little or no outside influence due to load change.

It is important to note that all adjustments of adjusting rings are GE’s initial adjustments only, and are not intended to be final adjustments. This final adjustment must be made on the operating system with conditions approximately those that will be realized under actual operating conditions. Valves are factory set for long blowdown to prevent chattering under initial setting conditions.

Factors which can affect valve operation, and which should be considered when initially setting a valve, are as follows:

1. Ambient temperature near the valve and valve temperature stabilization.
2. Line vibration.
3. Line capacity at time when the valve must lift.
4. Discharge stack or drain piping binding.
5. Fluid flow vibrations set up by upstream bends and other disturbances.

A.2 Popping Point Adjustment

Note: Prior to beginning this procedure, lower the operating pressure on the boiler to a point which ensures that the valve will not open during adjustment of the compression screw.

To change the popping pressure of the valve, remove the cap and lever assembly, loosen the compression screw locknut and turn the compression screw clockwise to increase the pop point, or counterclockwise to decrease the pop point.

After each adjustment of the compression screw, the lock nut should be tightened. The arm of the top spring washer should always be free from bearing against the yoke rod. This can be accomplished by holding a screw driver between the arm and the rod to prevent any movement of the top spring washer while adjusting the compression screw. Install the cap and lever assembly after set pressure adjustments have been completed, as outlined in the Re-Assembly instructions (See Section XV of this manual.)

XVI. Setting and Testing (Contd.)

⚠
WARNING

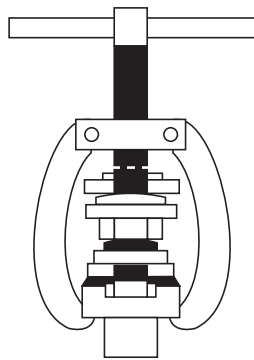

Gag safety valve during ring adjustments to avoid possible severe personal injury or death.

A.3 Ring Adjustments, Blowdown and Overlap Collar Adjustments

1. General

The positions of the upper adjusting ring and the lower adjusting ring are locked by means of the upper adjusting ring pin and the lower adjusting ring pin, respectively. These pins are threaded into the valve body and engage notches which are cut into the rings. To adjust either ring, the corresponding ring pin must be removed. A screw driver (or other suitable tool), inserted through the ring pin hole, can be used to turn the rings.

Note: Always gag the Safety Valve for protection. This will ensure that the disc is not accidentally lifted from the seat by the adjusting tool during ring adjustment. This will also ensure that an unexpected rise in system pressure will not be a hazard to service personnel.

2. Lower Ring Adjustment

If the lower adjusting ring position is in question, the factory position can be attained as follows:

- a. Gag the safety valve to prevent the disc from being accidentally lifted from the seat.
- b. Remove the service port plugs.
- c. Remove the lower adjusting ring pin.
- d. Move the lower adjusting ring up until it contacts the disc holder.
- e. Refer to Figure 33, and move the lower adjusting ring down the number of notches indicated in Column A, plus 1 additional notch for each 600 psig (41.37 barg) increment of set pressure, not to exceed six notches (see Table 12).
- f. Lock the lower adjusting ring into position by installing the lower adjusting ring pin, clockwise, until tight.
- g. Remove the gag.

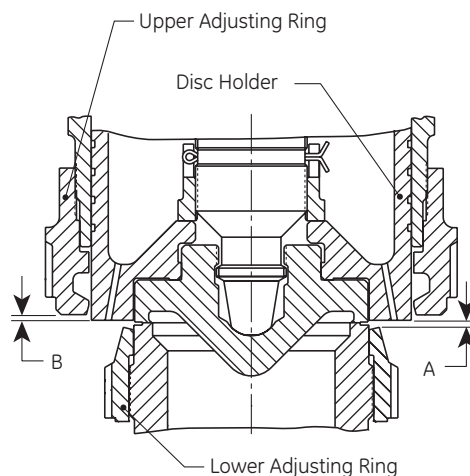

Figure 33

Table 12: Final Factory Positions (Field Starting Positions)		
Orifice	Lower Ring Holder to Seat in Notches (Column A)	Upper Ring Holder to Seat in Notches (Column B)
1	7	10
2	8	12
3	12	16
5	12	16
4	12	16
6	30	45
7	30	45
Q	30	45
8	37	45
R	38	47

XVI. Setting and Testing (Contd.)

- h. Test the valve on the system and adjust the lower ring to the lowest position which does not produce simmer. The ideal ring position must then be found by test for the set of operating conditions present. If simmer is present or the valve fails to lift, the lower ring should be moved upward slowly, one notch at a time, to remove the simmer. The most ideal position for the lower ring is the lowest position that does not introduce simmer or a buzzing sound.

3. Relationship Between Upper Ring and Overlap Collar Adjustments and Blowdown

The correct method of obtaining proper blowdown adjustment can be best explained by reference to Figure 34.

The upper ring is used to obtain full lift at the popping pressure. However, its position also determines the point at which the valve begins to drop out of full lift and starts the closing portion of its cycle. For example, if the upper ring is in such a position that the valve barely attains full lift at the popping pressure, and starts to drop out of full lift at a slight reduction of boiler pressure, the first portion of the valve cycle will be represented by the line ABF. If it were not for the lift stop, the action of the valve would be represented by the line ABCF. If the upper ring is in a more positive position (lower setting), the action of the valve would be represented by the line ABG and, if it were not for the lift stop, the line ABDG. If the upper ring is in a still lower position, the action of the valve is represented by the line ABH and, if it were not for the lift stop, ABEH. From this it can be seen that a lower position of the upper ring causes that valve to remain in full lift for a longer period of time and over a greater period of pressure reduction.

It will further be noted that there is a distinct difference between the actual overlap setting on the valve and the point at which the overlap begins to take effect. This can be understood since the area in the overlap vent begins to reduce considerably ahead of the point where the upper corner of the overlap bevel actually enters the floating washer. This has the effect of rounding off the corners of the diagram at points J, K & L. If the upper ring is in a position to produce the line ABH, the overlap will have to be set considerably higher to obtain a short blowdown than if the upper ring is set at such a position as to produce the line ABF. Excessive overlap settings may cause seat damage when the valve closes. It is therefore desirable to set the upper ring in such a position as to cause the valve to stay in full lift for as short a time as possible. The most desirous complete cycle is represented by the line ABFJM.

Note: When steam safety valves are subjected to an excessively high water level, the valve can be expected to have a long blowdown which the upper adjusting ring position will be unable to correct. It is recommended that the cause of high water level be corrected, so valves may function correctly at the ordered condition.

Note: If a superheater valve is set with low temperature steam, it is advisable to increase the blowdown to compensate for the change in density and other thermal effects taking place when the steam is brought up to working temperature. An approximate rule is to add 1/2 of 1% of set pressure to the blowdown for each 100°F (37.8°C) of steam temperature below the final temperature.

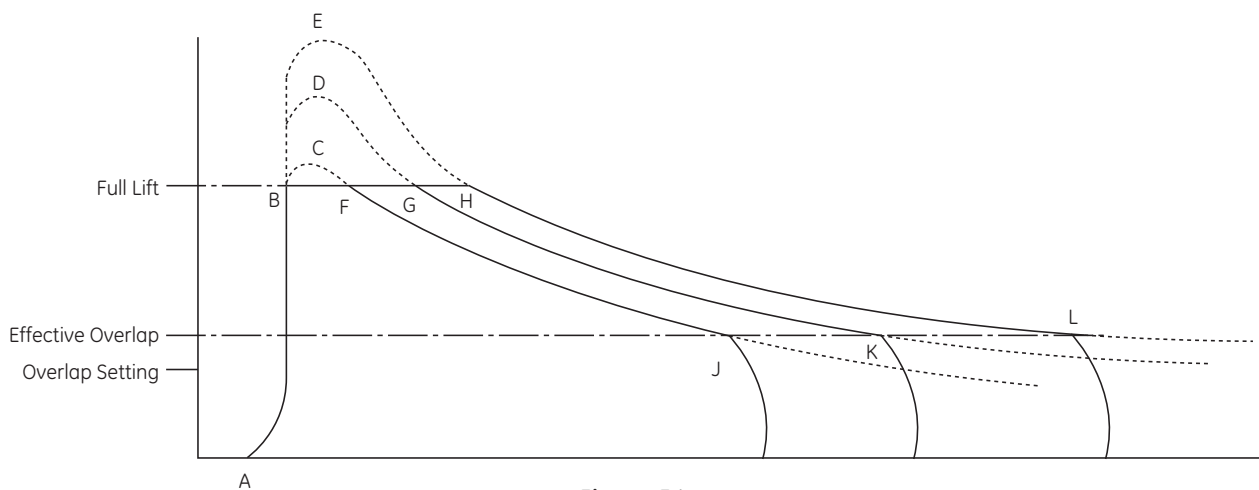
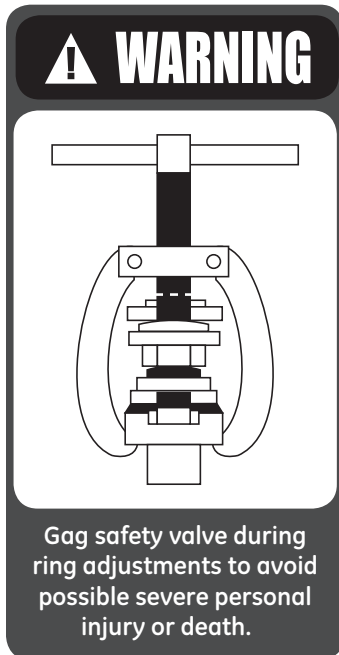

Figure 34

XVI. Setting and Testing (Contd.)



- 4 **Upper Ring Adjustment** If the upper adjusting ring position is in question, the factory position can be attained as follows:
 - a. Gag the safety valve to prevent the disc from being accidentally lifted from the seat.
 - b. Remove both service port plugs.
 - c. Remove upper adjusting ring pin.
 - d. Move the upper adjusting ring until it is level with the disc holder. A flashlight may be needed to provide adequate lighting for this observation. If so, the observation can be made from one of the service ports while the flashlight is positioned to shine through the other service port.
 - e. From this point, move the upper adjusting ring down the number of notches indicated by Column B of Table 12. This is also Dimension B in Figure 33.
 - f. Lock the upper adjusting ring into position by installing the upper adjusting ring pin.
 - g. Remove the gag.

5 **Blowdown Adjustments**

When further adjustments are required to obtain final blowdown setting, the upper adjusting ring should be moved 5-10 notches at a time as follows:

- a. To reduce blowdown: MOVE RING UP – TURN COUNTER CLOCKWISE.
- b. To increase blowdown: MOVE RING DOWN – TURN CLOCKWISE.

It is possible to raise the upper ring too far and prohibit attainment of full lift. When this occurs, lower the upper adjusting ring to the point where full lift is attainable and finalize the blowdown setting with the overlap collar adjustments. (See Section XVI.A3.6.) If the valve fails to lift, the lower adjusting ring requires further adjustment (See Lower Ring Adjustment.)

In attempting to obtain blowdown of 4%, it is important to be sure that the upper and lower adjusting ring positions are not so far apart as to cause loss of control of the valve. The first indication of reaching this condition is a slow “up and down hunting” action of the valve immediately before closing. If this action occurs at a blowdown longer than desired, moving both rings downward a small amount will generally produce a slightly shorter blowdown. When making this adjustment, move the upper ring twice as many notches as the lower.

After adjustments are complete, check the ring pins to see that they engage the ring grooves, but without touching the bottom of the groove. The pins should not bear against the rings.

6 **Overlap Collar Adjustment**

The overlap collar is a secondary adjustment point for blowdown control. It is utilized in conjunction with the upper adjusting ring. There will be some field conditions where it may not be necessary to use the overlap collar. However, in no case should the overlap collar be used exclusively for blowdown setting without first giving due adjustment attention to the upper adjusting ring.

The overlap collar is moved downward to shorten blowdown and upward to lengthen blowdown. After final setting, be sure to lock the overlap collar in position by installing the cotter pin.

A guide to how movement of the overlap collar assists in making final blowdown adjustments is as shown in Table 13.

XVI . Setting and Testing (Contd.)

Table 13: Movement of Overlap Collar

Orifice	Movement of Overlap Collar
1, 2 and 3	May not need further adjustment. If needed, move 1 notch at a time.
4 and 5	First adjustment 5 notches. Subsequent adjustments 2-3 notches each time.
6, 7, 8, Q and R	First and subsequent adjustment, 5-8 notches each time.

Note: The overlap collar position shown in Table 13, are final GE factory settings, but are only starting positions for field setting of blowdown. Further adjustment may be necessary as stated in Table 13.

A.4 Restricted Lift Valves

A Restricted Lift Valve is defined by a nameplate attached to the valve body. It reads: "Restricted lift Valves, see nameplate for lift".

As a starting position for the adjusting rings, use the method outlined in the this manual for the conventional valves (see Section XV.B).

A.5 Hydroset/EVT* Testing

Periodic test may be required for verification of valve set pressure both Consolidated Hydroset testing device and EVT unit provide for the this capability; however set pressure is the only factor which can be verified. Valves should be initially set using full system pressure (as outlined in sections XIII.A through XIII.C) and the Hydroset device or EVT, used for only subsequent checks of set pressure.

Setting safety valves by the usual method of lifting valves under steam pressure presents a number of problems. In high pressure conventional boilers, superheater tubes may be damaged if the turbine is not operating. Also the expense of feed water, fuel and personnel involved is considerable.

Although these problems cannot be eliminated entirely, they can be reduced by using a hydraulic or electronic device that allows the valve's set pressure to be checked while the system pressure remains below the valves set pressure.

Accuracy of result obtained by the use of either of these devices depends on several factors. First, friction

must be reduced as a source of error, so that, for a given pressure, the hydroset or the EVT repeatedly produces exactly the same lifting force. Second, gauge calibration and vibration and the effective seating area between valves of the same size and type will also affect accuracy.

With well calibrated gauges and valve seats in good condition, accuracy on the order of 1% oil set pressure may be expected. Upon request, GE will provide pertinent written material concerning the Consolidated Hydroset Device, or the EVT. This material specifies all required information necessary to ensure proper usage of the these devices.

A.6 Sealing Valves After Test

After testing the valve for proper set point and blowdown, the ring pins, overlap collar and top lever pin will be sealed to conform with the applicable ASME Code. In addition, the coverplate is sealed on restricted lift valves.

Means are provided in the design of all 1700 Series Maxiflow valves, for use under Section I of the ASME Code, for sealing all external adjustments. Seals are installed by GE at the time of shipment. It is also required that seals be installed, after field adjustment or repair of the valves, by the manufacturer, its authorized representative, or the user.

Seals should be installed in such a manner as to prevent changing the adjustment without breaking the seal. They also serve as a means of identifying the manufacturer, repairer or user making the adjustment.

Unauthorized breakage of the seals will void the valve warranty.



XVI. Setting and Testing (Contd.)

B. Hydrostatic Testing and Gagging

During any hydrostatic test, all safety valves on the unit, which have not been removed and do not have hydroplugs, must be gagged. This gagging procedure prevents the possibility of damage to the safety valve internals in the event that the test pressure exceeds the safety valve set pressure. When adjusting valve set pressures, other valves in the system should also be gagged.

When valves are subjected to working hydrostatic tests not exceeding the set pressure of the low set valve, valves may be gagged rather than using hydrostatic test plugs. For higher pressures, hydrostatic plugs should be used.

Probably the most common source of safety valve trouble is over-gagging. During hydrostatic testing, and during safety valve setting, gags should be applied only hand tight. During setting, over-gagging will also cause damage to the seating surface and result in seat leakage. In applying gags remember that the valve spring will hold the valve closed against its set pressure.

The additional gag load applied should be only enough to ensure that the valves do not lift at the expected overpressure.

During start-up, gags should never be applied when the boiler is cold. The spindle of the safety valve expands considerably with the temperature increase. If it is not free to expand with this temperature change it may become seriously overstressed and bent.

Except for hydrostatic tests, boiler pressure should be brought up to within 80% of the pressure of the low set valve before applying gags.

Tighten the gags of drum and superheater valves with only a light force applied to the gag screw head.

APPLICATION OF TEST GAGS (All Pressures)

Refer to Figure 37 on Section XVIII.B. Remove top lever pin and top lever then loosen the cap screw. Remove cap and drop lever as an assembly. The release nut is fixed to the spindle by means of a cotter pin. Note that the release nut does not quite engage top of compression screw.

Center the test gag in the exposed end of the spindle and hook the legs of gag under the sides of the yoke as shown in Figure 35.

Do not apply the gag load until the system steam pressure is equal to 80% of the pressure to which the low set valve is adjusted.

Apply the gag load by turning the gag screw clockwise. If the gag on any valve has not been tightened sufficiently, the valve will leak. On steam service the leakage is accompanied by a "sizzling" sound.

If this occurs, the hydrostatic test pressure or steam pressure should be reduced until the valve becomes tight and, then, the gag should be tightened still further.

This procedure must be followed exactly, since it is very difficult to stop the leak by additional gagging once it has started. Any attempt to stop the leakage through the valve, without first lowering the system pressure, could result in damage to the valve seats.

After the hydrostatic test or steam test is completed, the gags should be removed when the hydrostatic pressure has been reduced to 80% to 90% of the pressure of the low set valve.

Note: Under no circumstances should the gags be left on the valves.

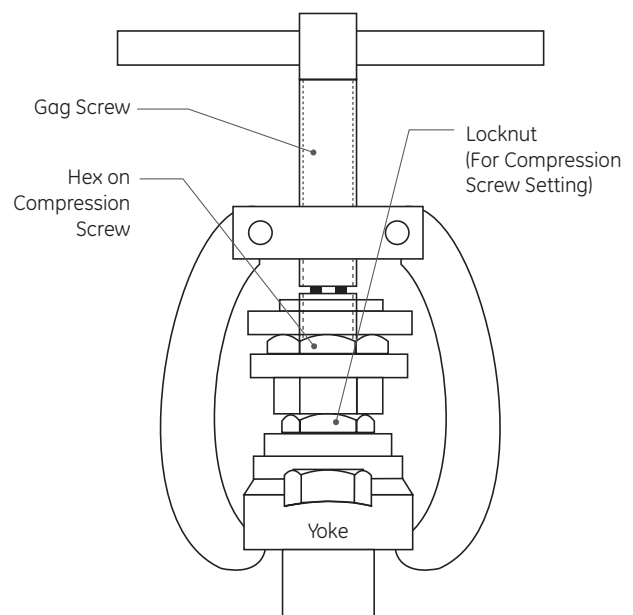

Figure 35: Test Gag

XVII. Troubleshooting the 1700 Series Safety Valves

Problem	Possible Cause	Corrective Action
No action, valve does not go into full lift.	A. Upper ring positioned too high.	A. Increase blowdown as outlined in Section XVI.A3.5.
	B. Foreign material trapped between disc holder and guide.	B. Disassemble valve and correct any abnormality as outlined in Section XII. Inspect system for cleanliness.
	C. Overlap collar adjusted too low.	C. Reset initial setting per Section XV.B.24, then move overlap collar from right to left one or two notches, then retest. Repeat additional adjustment as necessary.
Simmer	A. Lower ring too low.	A. Adjust per Section XVI.A3.2.
	B. Steam line vibrations.	B. Investigate and correct cause.
Valve leaking and/or exhibits erratic popping actions.	A. Damaged seat.	A. Disassemble valve, lap seating surfaces, replace disc if required, as outlined in Section XII.B.
	B. Part misalignment.	B. Disassemble valve, inspect contact area of disc and nozzle, lower spring washer or spindle, compression screw, spindle straightness, etc.
	C. Operating too close to set pressure.	C. Disassemble valve and check disc.
	D. Discharge stack binding on outlet.	D. Correct source of binding.
Hang-up, or valve does not close completely.	A. Lower ring too high.	A. Move lower ring to the left one notch per adjustment until problem is eliminated.
	B. Foreign material.	B. Disassemble valve and correct any abnormal condition. Inspect system for cleanliness.
	C. Improper disc/guide clearance.	C. Verify proper clearance.
Excessive blowdown	A. Upper ring too low.	A. Decrease blowdown as outlined in Section XVI.A3.4.
	B. Exhaust pressure too high.	B. Decrease exhaust pressure by increasing discharge stack area.
	C. Overlap collar too high.	C. Check initial setting per Section XV.B.24, then move overlap collar from right to left one or two notches, then retest. Repeat additional adjustment as necessary.
Chatter or short blowdown	A. Upper ring way too high.	A. Lower upper ring.
	B. Overlap collar way too low.	B. Raise overlap collar. Re-establish in accordance with Section XV.B.24.
	C. Inlet piping pressure drop too high.	C. Reduce inlet pressure drop to less than one-half of required valve blowdown by redesigning inlet piping.

XVIII. 1700 Series Safety Valve Options

A. Hydrostatic Test Plug

Flanged inlet safety valves should be removed from the boiler during hydrostatic tests and boiler nozzles blanked off to prevent possible valve damage.

All welded inlet valves are shipped with a hydroplug, unless otherwise specified. All flanged inlet valves are shipped without a hydroplug, unless otherwise specified.

Valves shipped with a hydroplug are identified by a Red on White CAUTION TAG which is attached to the valve by wires extending through the drain hole in the valve body. (See Figure 36.)

The hydrostatic plugs are placed in the bore of the valve, inside the seating surface. Their purpose is two

fold. First they affect closure at a point differing from the seating surface of the valve so that, if the valve is lifted on hydrostatic test, the seating surface is not as likely to be damaged. Second, by raising the disc of the valve off its seat and increasing spring compression, the set pressure of the valve is increased to a point where the valve will not leak at one and one-half times design boiler pressure. It is not necessary to gag safety valves tightly when hydrostatic plugs are used.

These plugs must, of course, be removed from the valves prior to placing the boiler in service. However, they should be retained, and reinstalled, whenever a hydrostatic test exceeding the low set valve pressure is conducted.

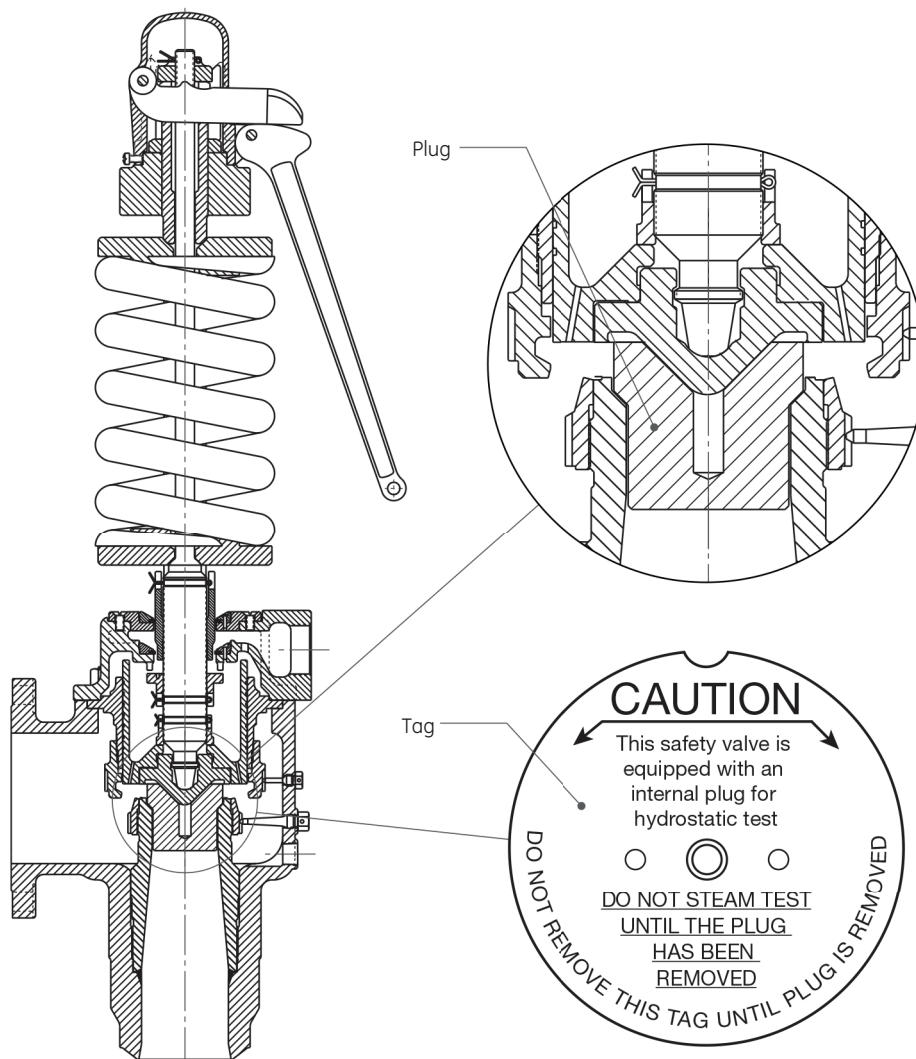

Figure 36: Hydrostatic Test Plug

XVIII. 1700 Series Safety Valve Options (Contd.)

B. Hydroplug

1. Disassemble the valve as outlined in Section XII of this manual.
2. Remove the hydrostatic test plug from the seat bushing, and lap disc and bushing seat.
3. Always be certain that all parts are clean and free of dirt and foreign material. Dirt trapped on seating surfaces or in the inlet, when the valve is reassembled, will damage the seats. Reassemble the valve as outlined in Section XV of this manual. The lug on the top spring washer should be on the left side of the valve when facing in the same direction as the outlet. (See Figure 37.)
4. Replace the cap, and locate the drop lever vertically on the center line of the valve.
5. Remove the top lever from the cap, and reassemble in position in accordance with Figure 37. If properly positioned, the top lever should have .125" (3.175 mm) of vertical movement prior to engaging bottom surface of release nut. The valve is now ready for the initial field test, on steam, to check valve set point and blowdown.

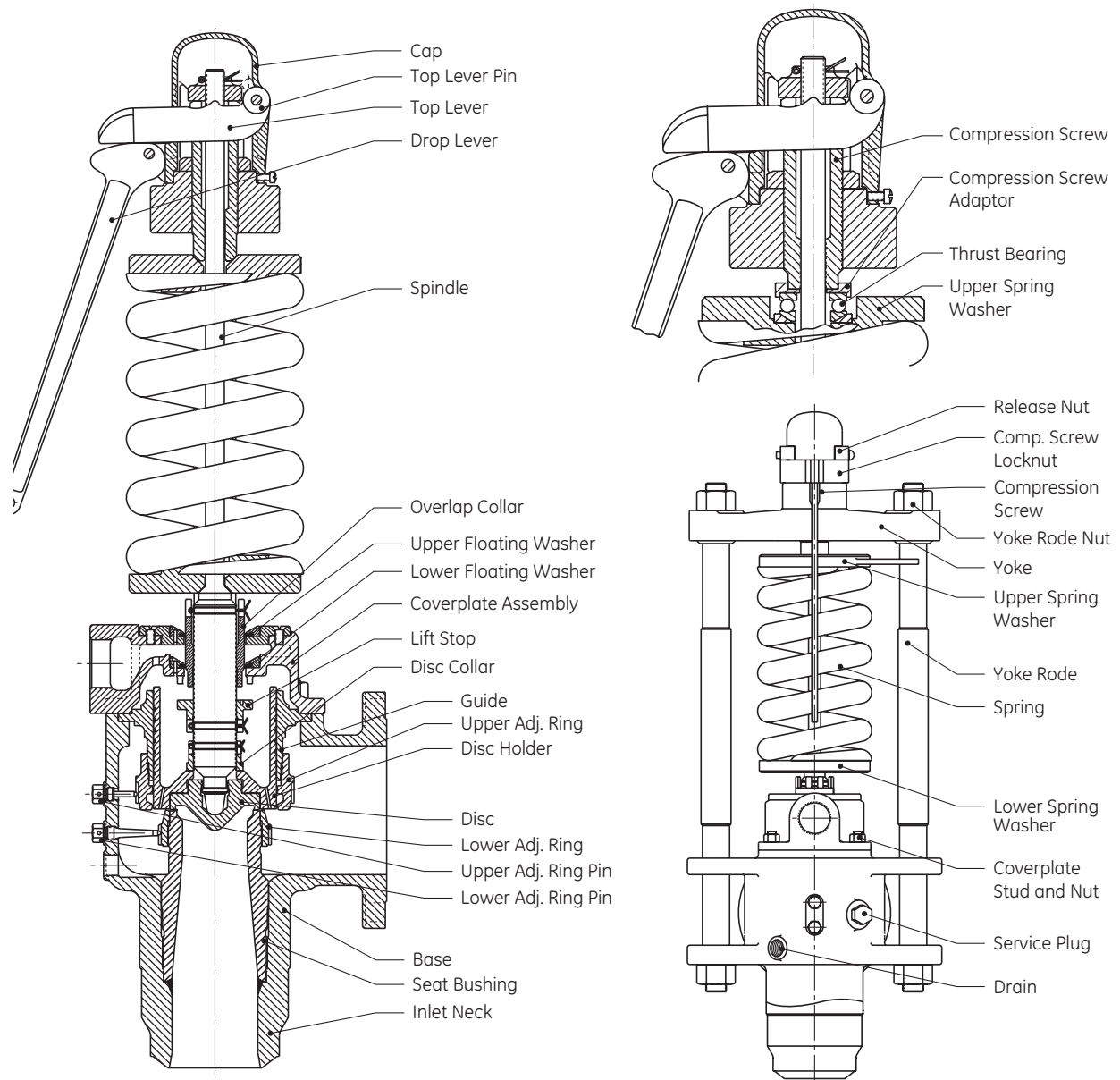

Figure 37: Hydroplug

XIX. Maintenance Tools and Supplies

A. Lapping Tools

The following tools are required for proper maintenance of Consolidated 1700 Series Safety Valve Seats:

A1. Ring Lap

The ring lap is used for lapping the nozzle and disc seats.

Valve Orifice ⁽²⁾	Lap Part No.
1	1672806
2	1672807
3	1672808
4	1672810
5	1672809
6	1672811
7 and Q	1672812
8, R and RR	1672813

⁽¹⁾ One set of two (2) Ring Laps is recommended for each orifice valve in service, to assure ample flat laps are available at all times.

⁽²⁾ Valve orifice number is third digit of valve type number, e.g. a 1737A valve has a #3 orifice.

A2. Lapping Plate

The lapping plate is used for reconditioning the ring laps. Only one 11.00" (279.4 mm) diameter plate is required for all sizes of ring laps.

Resurfacing Plate – 11" Diameter. Part No. 0439004

A3. Lapping Compound

Lapping compound is used as a cutting medium for lapping and polishing the seats and bearing surfaces in the 1700 Series safety valves.

Brand	Grade	Grit	Lapping Function	Size Container	Part No.
Clover	1A	320	General	4 oz.	1993
Clover	C	500	Finishing	4 oz.	1994
Kwik-AK Shun	--	1000	Polishing	1 lb.	19911
				2 oz.	19912

B. Gags

Valve Orifice ⁽¹⁾	Gag Part No.
1	4363001
2	4363001
3	4363001
4	4217701
5	4217701
6	4217701
7 and Q	4217701
8, R and RR	4217701

⁽¹⁾ Valve orifice number is third digit of valve type number, e.g. a 1737A valve has a #3 orifice.

C. Lubricant

Location	Lubricant
1. Spindle/Disc	Fel-Pro Nickel Ease
2. Compression Screw/Top Spring Washer	
3. Spindle/Bottom Spring Washer	
All Threads	
All Nut Contact Faces	

XIX. Maintenance Tools and Supplies (Contd.)

D. Wrench Sizes

Table 18: Wrench Sizes													
Maxiflow Series Number	Wrench Sizes [in (mm)]						Maxiflow Series Number	Wrench Sizes [in (mm)]					
	1.438	1.625	2.000	2.375	2.750	3.125		1.438	1.625	2.000	2.375	2.750	3.125
	(36.53)	(41.28)	(50.80)	(60.33)	(69.85)	(79.38)		(36.53)	(41.28)	(50.80)	(60.33)	(69.85)	(79.38)
1710							1748						
1712							1749						
1715													
1716							1750						
1717							1752						
1718							1755						
1719							1756						
							1757						
1720							1758						
1722							1759						
1725													
1726							1765						
1727							1766						
1728							1767						
1729													
							1775						
1730							1775Q						
1732							1776						
1735							1776Q						
1736							1777Q						
1737													
1738							1785						
1739							1786						
							1787						
1740													
1742							1705R						
1745							1706R						
1746							1707R						
1747													

XX. Replacement Parts Planning

The basic objectives in formulating a replacement parts plan are:

- PROMPT AVAILABILITY
- MINIMUM DOWNTIME
- SENSIBLE COST
- SOURCE CONTROL

Guidelines for establishing meaningful inventory levels:

Part Classification	Replacement Frequency	Predicted Availability
Class I	Most Frequent	70%
Class II	Less Frequent But Critical	85%
Class III	Seldom Replaced	95%
Class IV	Hardware	99%
Class V	Practically Never Replaced	100%

Consult the Recommended Spare Parts list (see Section XXII) to define the parts to be included in the inventory plan.

Select parts and specify quantities.

Identification and Ordering Essentials

When ordering service parts, please furnish the following information to ensure receiving the correct replacement parts:

Identify valve by the following nameplate data:

1. Size.
2. Type.
3. Temperature Class.
4. Serial Number.

Example One: 2" 1729WA S/N BG-5171

Example Two: 1 1/2" 1712WD
S/N BH-9547

Specify parts required by:

1. Part Name ((See Figures 1 to 5).
2. Part Number (if known).
3. Quantity.

Contact Parts Marketing: (318) 640-6044

In addition, the serial number is stamped on the top edge of the outlet flange. Be sure to include the one or two letters preceding the figures in the serial number. A typical valve nameplate is shown in Figure 38.

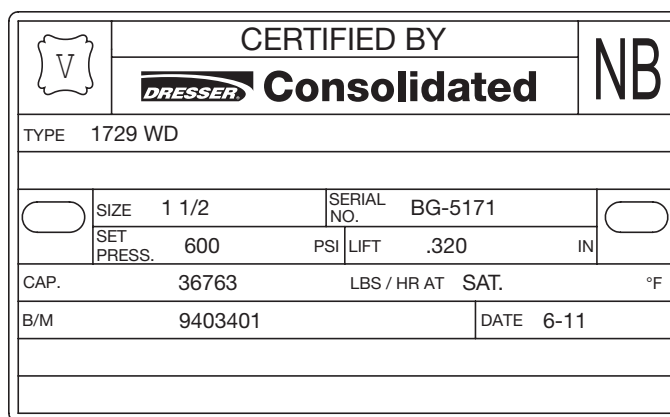

Figure 38: Valve Nameplate

XXI. Genuine Consolidated Parts

The next time replacement parts are needed, keep these points in mind:

- GE designed the parts.
- GE guarantees the parts.
- Consolidated valve products have been in use since 1879.
- GE has worldwide service.
- GE has fast response availability for parts.

XXII. Recommended Spare Parts

Table 20: Recommended Spare Parts					
Class	Part No. (1)	Part Name	Quantity Parts/Same Size, Type, Set Pressure and Temperature Class Valves in Service		
			Drum	Superheater	Reheat Section
I	8	Disc	1/1	1/1	1/4
	23	Adjusting Ring Pin (Upper)	1/1	1/1	1/4
	24	Adjusting Ring Pin (Lower)	1/1	1/1	1/4
II	2	Disc Holder	1/4	1/4	1/4
	4	Adjusting Ring (Upper)	1/4	1/4	1/4
	9	Adjusting Ring (Lower)	1/4	1/4	1/4
	12	Overlap Collar	1/4	1/4	1/6
	16	Spindle	1/2	1/2	1/6
	17	Spindle Button	1/2	1/2	1/6
III	3	Guide	1/4	1/4	1/4
	5	Spring	1/6	1/6	1/6
	10	Disc Collar	1/4	1/4	1/6
	11	Lift Stop	1/4	1/4	1/6
	18	Compression Screw	1/4	1/4	1/6
	26, 27	Spring Washers (2)	1 Set/6	1 Set/6	1 Set/6
	31	Thrust Bearing Cover	1/4	1/4	1/6
IV	15	Top Plate Screws	1 Set/4	1 Set/4	1 Set/6
	25	Compression Screw Locknut	1/4	1/4	1/6
		Cotter Pins	1 Set/4	1 Set/4	1 Set/6

⁽¹⁾ Refer to Figures 1 to 5 for the part numbers and their corresponding parts.

XXIII. Manufacturer's Service, Repair and Training Program

A. Field Service

Utilities and Process Industries expect and demand service at a moment's notice. GE's Field Service team can be depended upon for prompt response, even in extreme off-hour emergency situations.

GE maintains the largest and most competent field service staff in the industry. Service engineers are located at strategic points throughout the United States to respond to customer's requirements for service. Each service engineer is factory trained and long experienced in servicing safety valves. GE's engineers restore disc and seat bushing critical dimensions which affect valve performance, and are capable of modernizing valves in the field.

It is highly recommended that the professional talents of a GE field service engineer be employed to make final field adjustments during the initial setting of all Consolidated safety valves.

B. Factory Repair Facilities

GE's Consolidated factory maintains a GE Repair Center. The repair department, in conjunction with the manufacturing facilities, is equipped to perform specialized repairs and product modifications, e.g. bushing replacements, hydroset calibrations, electromatic relief valve repairs, code welding, pilot replacement, etc.

C. Maintenance Training

Rising costs of maintenance and repair in the utility and process industries indicate the need for trained maintenance personnel. GE conducts service seminars that can help your maintenance and engineering personnel to reduce these costs.

Seminars, conducted either at your site, or at our manufacturing plant, provide participants with an introduction to the basics of preventative maintenance. These seminars help to reduce downtime, reduce unplanned repairs, and increase valve safety. While they do not make "instant" experts, they do provide the participants with "Hands On" experience with Consolidated valves. The seminar also includes valve terminology and nomenclature, component inspection, troubleshooting, setting and testing, with emphasis on the ASME Boiler and Pressure Vessel Code.

For further information, please contact your local Green Tag Center or GE's Consolidated Training Manager at +1 (281) 542-3646.

DIRECT SALES OFFICE LOCATIONS

AUSTRALIA

Brisbane
Phone: +61-7-3001-4319
Fax: +61-7-3001-4399

Perth
Phone: +61-8-6595-7018
Fax: +61-8-6595-7299

Melbourne
Phone: +61-3-8807-6002
Fax: +61-3-8807-6577

BELGIUM
Phone: +32-2-344-0970
Fax: +32-2-344-1123

BRAZIL
Phone: +55-19-2104-6900

CHINA
Phone: +86-10-5689-3600
Fax: +86-10-5689-3800

FRANCE
Courbevoie
Phone: +33-1-4904-9000
Fax: +33-1-4904-9010

GERMANY
Ratingen
Phone: +49-2102-108-0
Fax: +49-2102-108-111

INDIA
Mumbai
Phone: +91-22-8354790
Fax: +91-22-8354791

New Delhi
Phone: +91-11-2-6164175
Fax: +91-11-5-1659635

ITALY

Phone: +39-081-7892-111
Fax: +39-081-7892-208

JAPAN
Tokyo
Phone: +81-03-6871-9008
Fax: +81-03-6890-4620

KOREA
Phone: +82-2-2274-0748
Fax: +82-2-2274-0794

MALAYSIA
Phone: +60-3-2161-0322
Fax: +60-3-2163-6312

MEXICO
Phone: +52-55-3640-5060

THE NETHERLANDS
Phone: +31-15-3808666
Fax: +31-18-1641438

RUSSIA
Veliky Novgorod
Phone: +7-8162-55-7898
Fax: +7-8162-55-7921

Moscow
Phone: +7 495-585-1276
Fax: +7 495-585-1279

SAUDI ARABIA
Phone: +966-3-341-0278
Fax: +966-3-341-7624

SINGAPORE
Phone: +65-6861-6100
Fax: +65-6861-7172

SOUTH AFRICA

Phone: +27-11-452-1550
Fax: +27-11-452-6542

SOUTH & CENTRAL
AMERICA AND THE CARIBBEAN
Phone: +55-12-2134-1201
Fax: +55-12-2134-1238

SPAIN
Phone: +34-93-652-6430
Fax: +34-93-652-6444

UNITED ARAB EMIRATES
Phone: +971-4-8991-777
Fax: +971-4-8991-778

UNITED KINGDOM
Bracknell
Phone: +44-1344-460-500
Fax: +44-1344-460-537

Skelmersdale
Phone: +44-1695-526-00
Fax: +44-1695-526-01

UNITED STATES
Jacksonville, Florida
Phone: +1-904-570-3409

Corpus Christi, Texas
Phone: +1-361-881-8182
Fax: +1-361-881-8246

Deer Park, Texas
Phone: +1-281-884-1000
Fax: +1-281-884-1010

Houston, Texas
Phone: +1-281-671-1640
Fax: +1-281-671-1735



*Denotes a trademark of the General Electric Company.

© 2017 General Electric Company. All rights reserved.

Other company names and product names used in this document are the registered trademarks or trademarks of their respective owners.